



USCO SpA



ITR PRODUCT CATALOGUE

G.E.T. CATALOGUE CATALOGO PARTI USURA

INDEX - 1

1) TIPS AND ADAPTERS	p.3
a) <i>Caterpillar Bucket and Ripper Tips</i>	p.5
b) <i>Caterpillar Shanks and Adapters</i>	p.17
c) <i>Caterpillar Tips and Adapters by Family</i>	p.22
d) <i>Caterpillar Ripper Tips by Machine</i>	p.23
e) <i>Komatsu Bucket and Ripper Tips</i>	p.24
f) <i>Komatsu Tips and Adapters by Machine</i>	p.25
g) <i>Komatsu Ripper Tips by Machine</i>	p.27
h) <i>Bofors Teeth and Adapters</i>	p.29
i) <i>Pins & Retainer</i>	p.32
l) <i>Fork Teeth</i>	p.35
2) CUTTING EDGES	p.37
a) <i>Profiles</i>	p.39
b) <i>Caterpillar Cutting Edges</i>	p.42
c) <i>Komatsu Cutting Edges</i>	p.47

...continued

41122 Modena Italy
via delle Nazioni, 65

ph +39 059 9780111
fax +39 059 9780061
@ info@usco.it

part number are for reference purposes only

www.usco.it



USCO SpA



ITR PRODUCT CATALOGUE

G.E.T. CATALOGUE CATALOGO PARTI USURA

INDEX – 2

3) END BITS	p.48
a) <i>Caterpillar End Bits</i>	p.50
b) <i>Caterpillar Grader End Bits</i>	p.51
c) <i>Komatsu End Bits</i>	p.52
4) GRADER BLADES	p.53
a) <i>Caterpillar Grader Blades and Grader end bits</i>	p.55
b) <i>Komatsu Grader Blades and Grader end bits</i>	p.56
c) <i>Grader Blades by Size</i>	p.57
5) RIPPER SHANKS	p.59
a) <i>Caterpillar Ripper Shanks</i>	p.61
b) <i>Komatsu Ripper Shanks</i>	p.62
6) PICKS FOR ROAD REHABILITATION	p.64



USCO SpA



ITR PRODUCT CATALOGUE

G.E.T. CATALOGUE CATALOGO PARTI USURA

1) TIPS AND ADAPTERS

- a) *Caterpillar Bucket and Ripper Tips*
- b) *Caterpillar Shanks and Adapters*
- c) *Caterpillar Tips and Adapters by Family*
- d) *Caterpillar Ripper Tips by Machine*
- e) *Komatsu Bucket and Ripper Tips*
- f) *Komatsu Tips and Adapters by Machine*
- g) *Komatsu Ripper Tips by Machine*
- h) *Bofors Teeth and Adapters*
- i) *Pins & Retainers*
- l) *Fork Teeth*



USCO SpA



ITR PRODUCT CATALOGUE

ITR BUCKET TIPS AND ADAPTERS



**The highest technical specifications
to guarantee the maximum wear life**

TIPS AND ADAPTERS ANALYSIS %

C	Mn	Si	Cr	Ni	Mo	P	S	Al
0.25~0.31	0.50~0.75	1.40~1.70	1.80~2.00	0.15~0.30	0.30~0.40	<0.035	<0.035	<0.035

41122 Modena Italy
via delle Nazioni, 65

ph +39 059 9780111
fax +39 059 9780061
@ info@usco.it

part number are for reference purposes only

www.usco.it



ITR PRODUCT CATALOGUE

1 a) Caterpillar Bucket and Ripper Tips

CAT J200: 416, 426, 428, 436, 910, 931, 935, 307

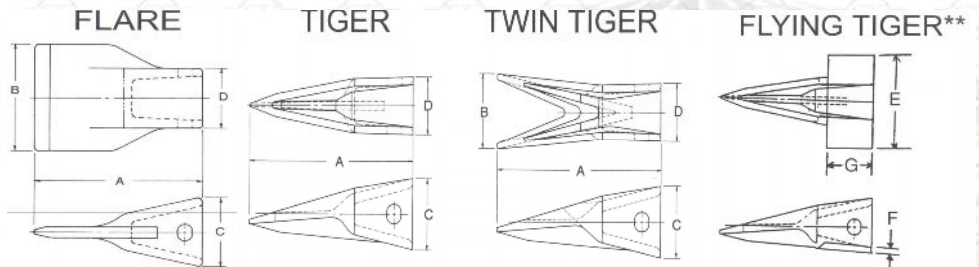

PART NUMBER	STYLE	WEIGHT	A	B	C	D	PIN	LOCK
1U3202	Long	1.4	14.4	4.9	6.4	6.0	8E6208	8E6209
1U3202F	Flare	1.3	12.7	11.1	5.9	6.0	8E6208	8E6209
1U3202FT	Flying Tiger	1.4	16.5		6.0	5.7	8E6208	8E6209
1U3202T	Tiger	1.1	16.5		6.0	5.7	8E6208	8E6209
1U3202WT	Twin Tiger	1.4	16.5	7.6	6.0	5.7	8E6208	8E6209
1358208	Twin Tiger							
1358203	Unitooth B/O	2.6	BOLT	4F3656	NUT	5P8362		

CAT J225: 446, 933

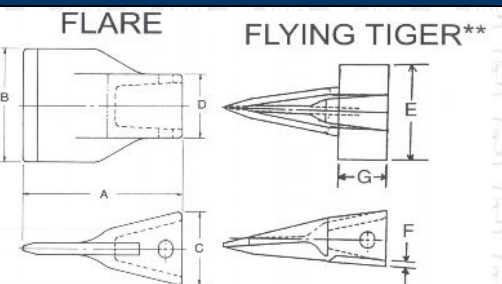

PART NUMBER	STYLE	WEIGHT	A	B	C	D	PIN	LOCK
6Y3222	Long	1.9	16.8	5.7	8.1	6.5	6Y3228	8E6259
6Y3222F	HD Flare	2.7	14.6	11.7	8.1	6.7	6Y3228	8E6259
6Y3222FT	Flying Tiger	2.5	20.0		8.1	6.6	6Y3228	8E6259

...continued



USCO SpA



ITR PRODUCT CATALOGUE

CAT J250: 916 THRU 930, 936, 941, 943, 951, 953, 205 THRU 241, 225, 229, 311, 312, 320



FLYING TIGER**

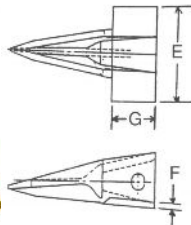

TIGER

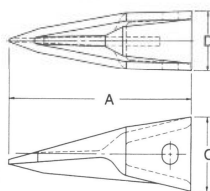

TWIN TIGER

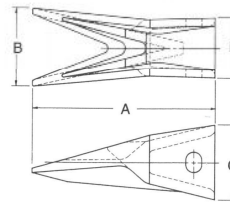

RC

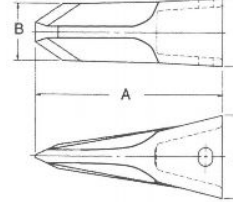

PENETRATION

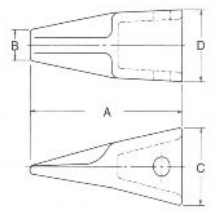

PART NUMBER	STYLE	WEIGHT	A	B	C	D	PIN	LOCK
1U1857								
1U3251	Short	2.1	16.2	6.5	8.3	7.3	8E6258	8E6259
1U3252	Long	3.0	19.5	6.2	8.7	7.1	8E6258	8E6259
1U3252FT	Flying Tiger	4.1	20.3		10.0	7.3	8E6258	8E6259
1U3252RC	Rock Chisel	3.9	21.6	5.4	9.0	7.5	8E6258	8E6259
1U3252T	Tiger	3.4	20.3		10.0	7.3	8E6258	8E6259
1U3252WT	Twin Tiger	3.4	20.3	8.9	8.4	7.3	8E6258	8E6259
3G8250	Flare	3.8	19.7	11.6	8.9	7.1	8E6258	8E6259
4T2253PT	ABR/Penetration	5.2	23.3	6.7	9.4	7.6	8E6258	8E6259
9J4253	Abrasion	3.2	19.1	7.6	8.3	7.6	8E6258	8E6259
9J4259	Penetration	2.3	19.5	3.2	8.6	7.6	8E6258	8E6259
9N4252	HD Long	3.9	20.0	6.0	9.4	7.6	8E6258	8E6259
9N4253	HD Abrasion	4.4	18.9	7.8	8.4	7.6	8E6258	8E6259

...continued

41122 Modena Italy
via delle Nazioni, 65

ph +39 059 9780111
fax +39 059 9780061
@ info@usco.it

part number are for reference purposes only

www.usco.it



USCO SpA



ITR PRODUCT CATALOGUE

CAT J300: 950, 953B THRU 966, E180, 215, 219, 235, 205 THRU 214, 315, 320, 322



FLYING TIGER**

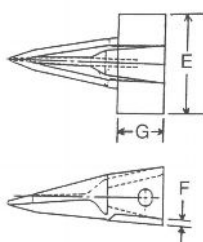

RC

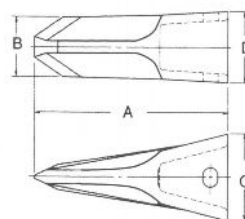

SYL

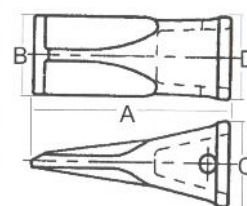

TIGER

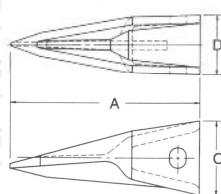

TWIN TIGER

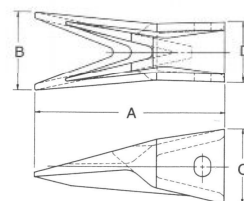

PENETRATION

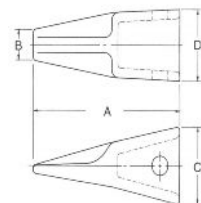

PART NUMBER	STYLE	WEIGHT	A	B	C	D	PIN	LOCK
1U1877								
1U3301	Short	3.6	18.9	7.6	10.0	8.7	9J2308	8E6259
1U3302	Long	4.3	21.3	7.9	10.2	8.6	9J2308	8E6259
1U3302FT	Flying Tiger	5.4	24.1		10.5	11.4	9J2308	8E6259
1U3302RC	Rock Chisel	5.6	24.8	7.3	10.6	8.7	9J2308	8E6259
1U3302SYL	Excavator Long	4.4	22.9	9.4	10.2	9.2	9J2308	8E6259
1U3302TL	Tiger Long	4.2	24.1		10.5	11.4	9J2308	8E6259
1U3302WTL	Twin Tiger Long	4.8	24.1	10.6	10.6	11.3	9J2308	8E6259
4T1300	Flare	5.2	21.6	15.2	9.8	8.6	9J2308	8E6259
4T2303	Abrasion	5.0	22.0	10.2	9.8	9.0	9J2308	8E6259
4T2303PT	ABR/Penetration	7.6	26.0	8.4	11.0	8.9	9J2308	8E6259
9J4309	Penetration	3.9	22.1	4.0	10.3	8.9	9J2308	8E6259
9N4302	HD Long	5.5	22.1	7.0	10.5	11.4	9J2308	8E6259
9N4303	HD Abrasion	6.7	22.5	10.8	10.2	8.6	9J2308	8E6259

...continued

41122 Modena Italy
via delle Nazioni, 65

ph +39 059 9780111
fax +39 059 9780061
@ info@usco.it

part number are for reference purposes only

www.usco.it



USCO SpA



ITR PRODUCT CATALOGUE



CAT J350: 966B, 977, 980, E180, E240, 213B, 215 THRU 229, 320, 322, 325, 330



FLYING TIGER**

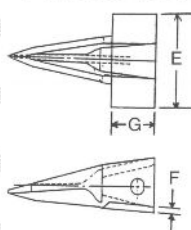

RC

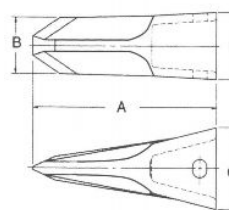

SYL

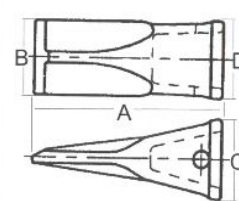

TIGER

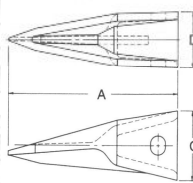

TWIN TIGER

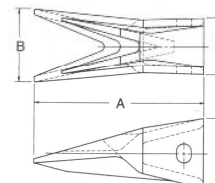

PENETRATION

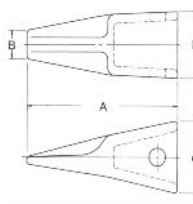

PART NUMBER	STYLE	WEIGHT	A	B	C	D	PIN	LOCK
1U3351	Short	4.5	20.2	8.9	10.5	9.7	8E6358	8E6359
1U3352	Long	6.3	24.1	9.4	11.0	10.2	8E6358	8E6359
1U3352FT	Flying Tiger	8.9	27.9		11.3	10.5	8E6358	8E6359
1U3352RC	Rock Chisel	8.1	27.9	8.6	11.3	10.2	8E6358	8E6359
1U3352SYL	Excavator Long	8.6	26.4	10.6	11.6	10.0	8E6358	8E6359
1U3352T	Tiger	7.4	28.9		11.1	10.6	8E6358	8E6359
1U3352TL	Tiger Long	6.0	28.6		11.0	10.2	8E6358	8E6359
1U3352WT	Twin Tiger	7.5	27.3	12.1	11.4	10.3	8E6358	8E6359
4T2353PT	ABR/Penetration	9.7	29.1	9.7	11.3	10.2	8E6358	8E6359
6Y0649								
9J4359	Penetration	5.4	24.4	4.8	11.3	10.2	8E6358	8E6359
9N4352	HD Long	8.4	25.6	8.7	11.7	10.0	8E6358	8E6359
9N4353	HD Abrasion	10.8	25.4	12.2	11.6	10.2	8E6358	8E6359
1073350	Flare	7.5	24.1	17.8	11.4	10.2	8E6358	8E6359
1359357	Twin Tiger Long	6.8	28.6	12.1	11.0	10.2	8E6358	8E6359

...continued

41122 Modena Italy
via delle Nazioni, 65

ph +39 059 9780111
fax +39 059 9780061
@ info@usco.it

part number are for reference purposes only

www.usco.it



USCO SpA



ITR PRODUCT CATALOGUE

CAT J400: 980G, 322, 325, 330

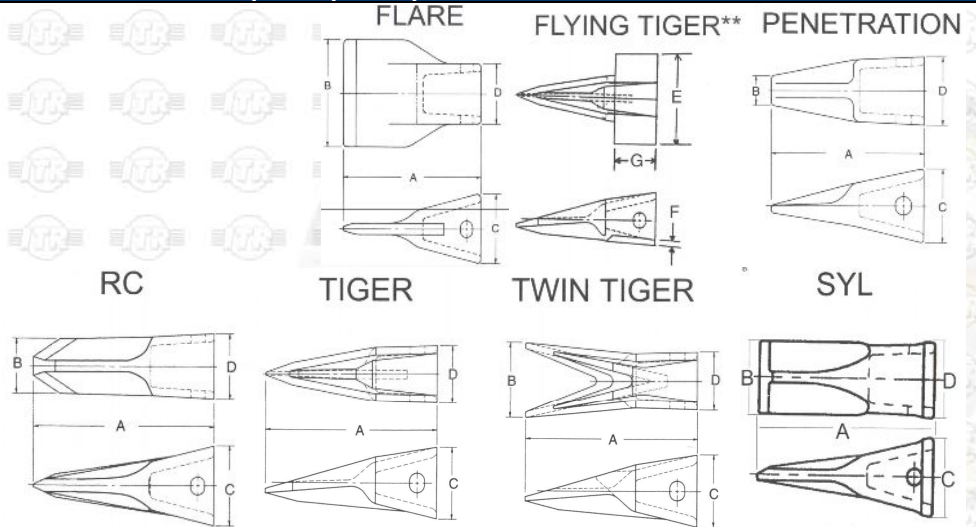

PART NUMBER	STYLE	WEIGHT	A	B	C	D	PIN	LOCK
1359408	Twin Tiger Long	10.7	31.3	13.8	13.2	11.7	7T3408	8E8409
6Y7409	Penetration	8.3	16.7	5.4	13.0	11.7	7T3408	8E8409
7T3402	Long	8.4	26.2	10.3	12.4	11.6	7T3408	8E8409
7T3402F	HD Flare	11.5	26.2	21.0	12.5	11.9	7T3408	8E8409
7T3402FT	Wing Tip	11.9	31.4		13.5	12.4	7T3408	8E8409
7T3402PT	ABR/Penetration	13.9	32.1	10.8	12.4	11.7	7T3408	8E8409
7T3402RC	Rock Chisel	11.7	30.8	9.8	12.9	11.7	7T3408	8E8409
7T3402TL	Tiger Long	9.7	32.5		13.3	11.9	7T3408	8E8409
8E4402	HD Long	11.3	28.3	10.2	13.3	12.4	7T3408	8E8409
8E4402SYL	Excavator Long	12.9	30.5	12.1	13.3	12.4	7T3408	8E8409

...continued

41122 Modena Italy
via delle Nazioni, 65

ph +39 059 9780111
fax +39 059 9780061
@ info@usco.it

part number are for reference purposes only

www.usco.it



USCO SpA



ITR PRODUCT CATALOGUE

CAT J450/460: 983, 988, 988B, 225, E300, 235, 325, 330, 345, 350

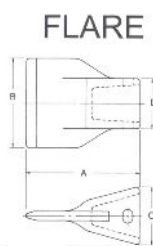

FLYING TIGER***

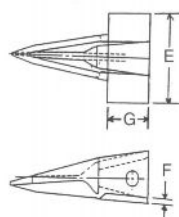

RC

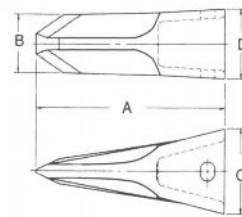

TIGER

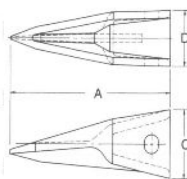

TWIN TIGER

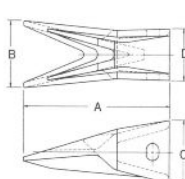

PENETRATION

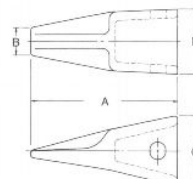

SYL

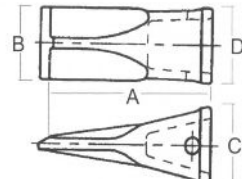

PART NUMBER	STYLE	WEIGHT	A	B	C	D	PIN	LOCK
1386451	HD ABR/Penetration	21.8	35.6	12.7	15.1	14.3	8E0468	8E8469
1386458	Twin Tiger Long	14.9	35.7	16.4	13.7	13.3	6Y2527	8E6359
1U3452F	HD Flare	15.5	28.6	22.9	13.2	13.0	6Y2527	8E6359
1U3452FT	Flying Tiger	12.9	33.8		13.5	13.2	6Y2527	8E6359
1U3452RC	Rock Chisel	14.1	33.0	10.8	13.7	13.2	6Y2527	8E6359
1U3452TL	Tiger Long	13.3	35.7		13.7	13.3	6Y2527	8E6359
1U3452WT	Twin Tiger	11.2	30.5	39.8	12.7	13.0	6Y2527	8E6359
9N4452	HD Long	16.4	31.6	11.7	14.0	13.3	6Y2527	8E6359
9N4453	HD Abrasion	21.0	31.3	16.5	14.3	13.2	6Y2527	8E6359
9W1453PT	ABR/Penetration	22.3	35.4	13.0	14.8	13.7	8E0468	8E8469
9W8451	Short	11.4	26.7	11.7	12.5	13.2	6Y2527	8E6359
9W8452	Long	12.2	29.2	11.0	12.7	12.5	6Y2527	8E6359
9W8452SYL	Excavator Long	13.4	32.2	13.2	14.1	13.2	6Y2527	8E6359
9W8452T	Tiger	11.3	32.7		13.5	13.0	6Y2527	8E6359
9W8459	Penetration	12.6	29.4	5.4	13.7	12.5	6Y2527	8E6359

...continued

41122 Modena Italy
via delle Nazioni, 65

ph +39 059 9780111
fax +39 059 9780061
@ info@usco.it

part number are for reference purposes only

www.usco.it



USCO SpA



ITR PRODUCT CATALOGUE

CAT J550: 988G, 992, 235, 245, 345, 350, 375

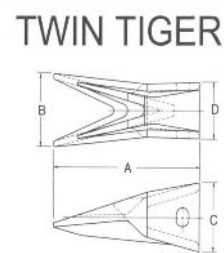
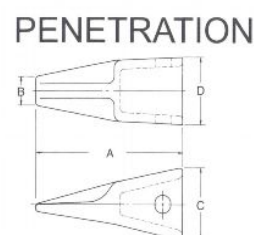
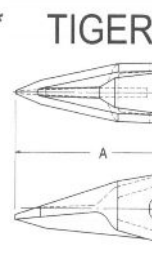
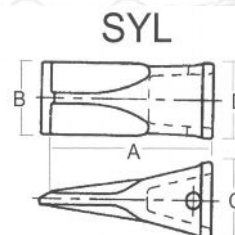
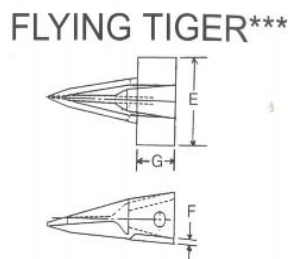
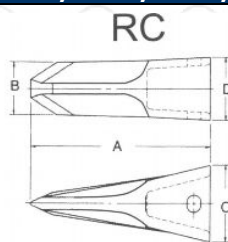
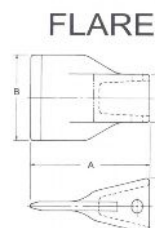

PART NUMBER	STYLE	WEIGHT	A	B	C	D	PIN	LOCK
1386552	HD ABR/Penetration	30.6	38.7	14.0	16.5	16.0	6Y8558	8E5559
1U3552F	HD Flare	29.3	34.9	27.9	15.6	16.0	6Y8558	8E5559
1U3552FT	Flying Tiger	24.4	38.4		16.2	16.0	6Y8558	8E5559
1U3552RC	Rock Chisel	22.5	38.1	13.0	15.6	15.9	6Y8558	8E5559
1U3552TL	Tiger Long	16.5	38.1		14.6	15.6	6Y8558	8E5559
1U3552WT	Twin Tiger	15.9	33.7	17.0	13.6	15.2	6Y8558	8E5559
2227553	Twin Tiger Long	17.3	38.1	18.4	14.6	15.6	6Y8558	8E5559
6Y2553	Abration	31.0	34.4	19.1	15.9	15.9	6Y8558	8E5559
9N4552	HD Long	24.4	37.0	14.0	16.2	15.9	6Y8558	8E5559
9W1553PT	ABR/Penetration	27.3	36.0	14.0	15.4	16.0	6Y8558	8E5559
9W8551	Short	17.9	28.7	14.1	14.6	15.2	6Y8558	8E5559
9W8552	Long	18.6	33.5	14.3	14.6	15.4	6Y8558	8E5559
9W8552SYL	Excavator Long	21.0	36.5	15.6	15.2	15.7	6Y8558	8E5559
9W8552T	Tiger	21.0	39.4		16.2	16.0	6Y8558	8E5559
9W8559	Penetration	14.5	33.7	6.5	14.1	15.1	6Y8558	8E5559

...continued

41122 Modena Italy
via delle Nazioni, 65

ph +39 059 9780111
fax +39 059 9780061
@ info@usco.it

part number are for reference purposes only

www.usco.it



ITR PRODUCT CATALOGUE

CAT J600: 992, 375



TIGER

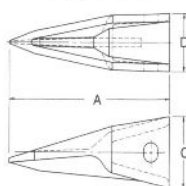

TWIN TIGER

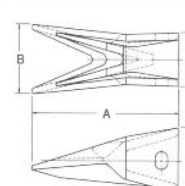

PENETRATION

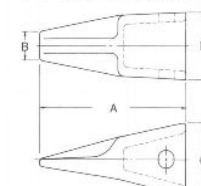

PART NUMBER	STYLE	WEIGHT	A	B	C	D	PIN	LOCK
6I6602TL	Tiger Long	33.6	45.7		18.4	19.7	6I6608	6I6609
6I6602WTL	Twin tiger Long	35.9	46.4	23.3	18.4	19.8	6I6608	6I6609
6I6603PT	ABR/Penetration	57.7	47.0	16.2	18.4	19.8	6I6608	6I6609
7I7609	Penetration	26.3	39.4	8.6	18.4	19.1	66I6608	6I6609
7Y0602	HD Long	41.4	40.6	16.5	19.1	19.1	66I6608	6I6609
6I6602	Long	33.5	38.1	16.5	18.6	19.7	6I6608	6I6609
1359600	HD ABR/Penetration	56.0	45.1	15.9	19.1	19.1	6I6608	6I6609

CAT J700: 992G, 994, 375 (VMX Bucket)



PENETRATION

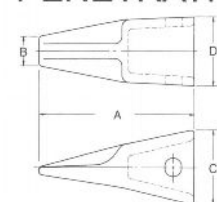

PART NUMBER	STYLE	WEIGHT	A	B	C	D	PIN	LOCK
1359700	HD ABR/Penetration	63.9	50.8	17.8	21.6	20.3	4T4708	4T4707
4T4702	Long	36.9	41.9	18.1	21.3	20.0	4T4708	4T4707
4T4703	Abrasion	48.6	41.8	22.9	21.6	20.2	4T4708	4T4707
4T4703PT	ABR/Penetration	55.6	50.2	7.6	21.6	21.0	4T4708	4T4707
4T4709	Penetration	38.7	31.8	8.3	21.6	21.0	4T4708	4T4707

CAT J800: 994

PART NUMBER	STYLE	WEIGHT	A	B	C	D	PIN	LOCK
6I8803	Abrasion	101.7	31.8	29.2	24.1	24.4	1341808	1341809



ITR PRODUCT CATALOGUE

CAT STYLE RIPPER TOOTH AND SHANK for 951, 955, 140, 140G



Type 2- Penetration Ripper Tooth

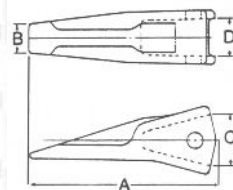

PART NUMBER	TYPE	STYLE	WEIGHT	A	B	C	D	PIN	LOCK
6Y0309	2	Penetration	5.2	29.2	5.1	7.9	6.0	9W2668	8E6359
9J6586		Shank	23.1					9W2668	8E6359
9J8913		Shank	26.1					9W2668	8E6359
1957218 DT		Shank							
1957218		Shank							

CAT STYLE RIPPER TEETH AND SHANK for D5, D6, D7, 973, 977, 14G, 16G



Type 1- Centerline Ripper Tooth

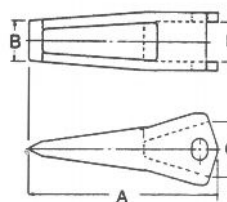

Type 3- Ripper Tooth

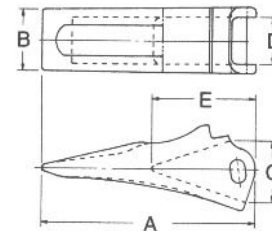

PART NUMBER	TYPE	STYLE	WEIGHT	A	B	C	D	PIN	LOCK
6Y0359	1	Penetration	11.6	36.2	5.4	11.1	7.6	8E6358	8E6359
6Y0352	1	Penetration	10.8	35.6	4.8	11.3	7.9	8E6358	8E6359
7J3312	3		14.4	35.3	8.4	9.9	7.6	4T2479	N/A
9J3139		Shank	60.3						
9W7382		Shank	137.3						



USCO SpA



ITR PRODUCT CATALOGUE

CAT STYLE RIPPER TEETH AND FIELD REPAIR NOSE ADAPTER for D8, D8K, D8L, D8N, D8R, D9, D9H, D9N, D9R



Type 2- Penetration Ripper Tooth

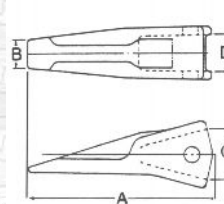

Type 1- Centerline Ripper Tooth

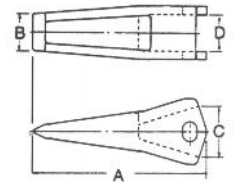

PART NUMBER	TYPE	STYLE	WEIGHT	A	B	C	D	PIN	PROTECTOR
1140453		Long	15.8	42.2	8.6	12.4	8.6	4T4279	6J8814
4T5452	2	Intermediate	15.2	39.7	5.4	12.4	8.6	4T2479	6J8814
8E5346		Shank	289.8						
8E8418		Repair Nose	7.3	36.2	59.4	7.6			
9W2451	1	Short	14.5	33.0	7.9	12.4	8.6	4T2479	6J8814
9W2452	1	Intermediate	16.4	37.6	9.0	12.4	8.6	4T2479	6J8814

...continued

41122 Modena Italy
via delle Nazioni, 65

ph +39 059 9780111
fax +39 059 9780061
@ info@usco.it

part number are for reference purposes only

www.usco.it



ITR PRODUCT CATALOGUE

CAT STYLE RIPPER TEETH for D9L, D10, D11



Type 1- Centerline Ripper Tooth

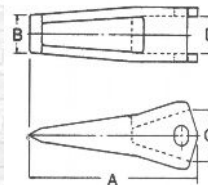

Type 2- Penetration Ripper Tooth

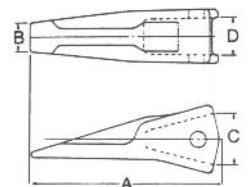

PART NUMBER	TYPE	STYLE	WEIGHT	A	B	C	D	PIN	LOCK
4T4502	1	Intermediate	29.7	43.2	7.6	16.8	10.8	3G0500	N/A
4T5501	2	Short	23.8	37.5	8.1	16.8	10.8	3G0500	N/A
4T5502	2	Intermediate	27.1	43.0	7.6	16.8	10.8	3G0500	N/A
4T5503	2	Long	27.8	46.5	7.6	16.8	10.8	3G0500	N/A
8E8503	1	Long	29.7	48.3	7.6	16.8	10.8	3G0500	N/A
9W4551	1	Short	39.8	44.8	7.6	16.8	21.3	6Y2443	

...continued



USCO SpA



ITR PRODUCT CATALOGUE

CAT STYLE RIPPER PROTECTORS



PART NUMBER	STYLE	WEIGHT	A	B	C	D	PIN	LOCK
6J8814		11.0					6Y3394	8E4743
6Y8960		36.0					6Y3909	4T4707
8E1848		20.8					4T2479	
9N4621		76.1					8E2229	8E2230
9W8365		39.1					6Y3909	4T4707

CAT COMPACTOR-WELD ON



Type 1 - Weld-on

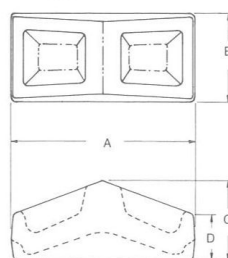

Type 2 - Bolt-on

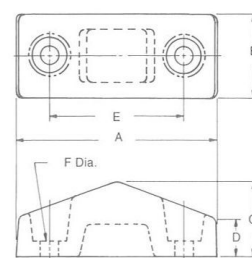

PART NUMBER	TYPE	STYLE	WEIGHT	A	B	C	D	E	F
8K9189	2	815, 815F Foot BOLT - 7k6692	3.9	17.0	7.0 6.4		3.2	11.4	1.7
2V6628	2	825,835 BOLT - 0T0856	5.7		WASHER-5S0581				
2V7053	1	815B Foot	4.1	16.8	8.1	7.1	4.1		

41122 Modena Italy
via delle Nazioni, 65

ph +39 059 9780111
fax +39 059 9780061
@ info@usco.it

part number are for reference purposes only

www.usco.it



ITR PRODUCT CATALOGUE

1 b) Caterpillar Shanks and Adapters

CAT STYLE BOLT ON CENTER ADAPTERS

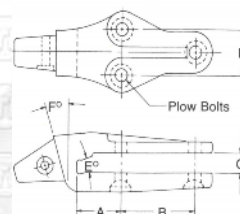

TYPE 5

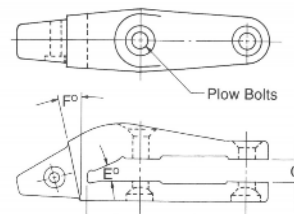

TYPE 6

PART NUMBER	FAMILY & TYPE	WEIGHT	A	B	C	D	BOLT	NUT
8E2184	J200 6	2.2	5.1	7.6	0.8		4F3656	4K0367
9J4207	J200 6	3.4	6.7	8.9	0.8		2J4771	2J3506
1U0257	J250 6	8.3	7.0	12.4	2.7		5P8136	8J2933
3G5307	J300 5	13.5	8.6	14.6	2.5		5P8136	8J2933
1U0307	J300 6	10.6	7.0	12.4	2.7		5P8136	8J2933
3G9307	J300 6	11.8	8.6	16.0	3.3		5P8361	5P8362
4T4307	J300 6	12.1	8.6	16.5	3.3		5P8136	8J2933
9J2307	J300 6	11.6	24.1	7.6	2.9		1J3527	2J3507
1700073	J350 6	20.8	8.6	15.9	3.2		6V8360	5P8362
1U1357	J350 6	20.1	10.3	15.6	4.6		5P8361	5P8362
3G3357	J350 6	15.7	9.8	14.9	4.3		5P8361	5P8362
6I9898	J400 6	24.7	10.4	15.6	3.2		5P8361	5P8362

...continued



USCO SpA



ITR PRODUCT CATALOGUE



CAT STYLE BOLT ON CONRNER ADAPTERS

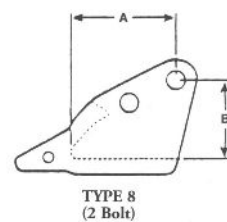
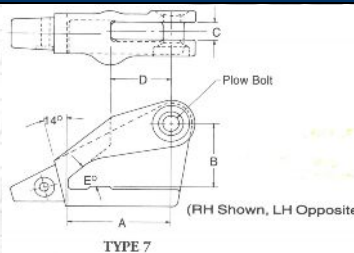

PART NUMBER	FAMILY & TYPE	WEIGHT	A	B	C	D OR BOLT	BOLT	NUT
1U2208	J200 7L	3.8	12.1	5.6	0.8		6F0196	2J3505
1U2209	J200 7R	3.8	12.1	5.6	0.8		6F0196	2J3505
3G4258	J250 7L	10.3	14.6	10.6	2.7	7.6	4J9058	8J2933
3G4259	J250 7R	10.3	14.6	10.6	2.7	7.6	4J9058	8J2933
6I9250	J250 8L	13.1	19.1	16.8		4J9058	4F4042	2J3507
6I9251	J250 8R	13.1	19.1	16.8		4J9058	4F4042	2J3507
3G4308	J300 7L	17.0	17.8	12.1	2.7	10.3	5P8823	5P8362
3G8308	J300 7I	16.2	20.3	14.0	4.0	13.0	5P8823	5P8362
3G8309	J300 7R	16.2	20.3	14.0	4.0	13.0	5P8823	5P8362
8E5308	J300 8L	16.7	20.0	16.4		8T9079	5P8823	3K9770
8E5309	J300 8R	16.7	20.0	16.4		8T9079	5P8823	3K9770
3G5358	J350 7L	22.6	21.6	1.6	4.0	13.0	5P8823	5P8362
3G5359	J350 7R	22.6	21.6	1.6	4.0	13.0	5P8823	5P8362
8E5358	J350 8L	24.6	14.0	20.3		6V6535	5P8361	3K9770
8E5359	J350 8R	24.6	14.0	20.3		6V6535	5P8361	3K9770
6I8243	J400 8L	37.4	6.4	20.6		5P8361	6V6535	3K9770
6I8244	J400 8R	37.4	6.4	20.3		5P8361	6V6535	3K9770
3G4309	J600 7R	17.0	17.8	12.1	2.7	10.3	5P8823	5P8362
3G0169	J250 4	4.3	19.1	5.9	5.1	0.8	22°	15°

CAT STYLE WELD ON BOTTOM LEG ADAPTERS

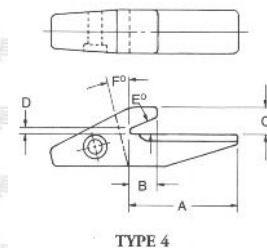
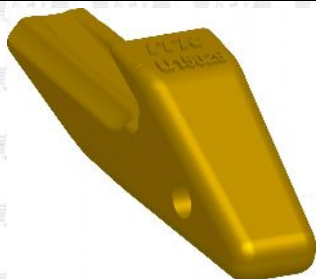

PART NUMBER	FAMILY & TYPE	WEIGHT	A	B	C	D	E	F
8J7525	J200 4	1.6	10.0	2.5	2.5	0.6	23°	14°

41122 Modena Italy
via delle Nazioni, 65

ph +39 059 9780111
fax +39 059 9780061
@ info@usco.it

part number are for reference purposes only

www.usco.it



USCO SpA



ITR PRODUCT CATALOGUE



CAT STYLE WELD ON CENTER DOUBLE STRAPPED ADAPTERS

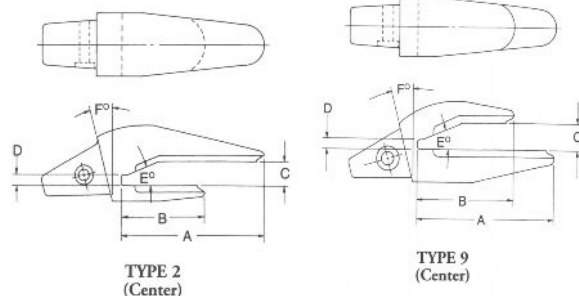

PART NUMBER	FAMILY & TYPE	WEIGHT	A	B	C	D	E	F
6Y3224	J220 9	3.3	13.5	8.7	2.7	1.1	22°	8°
1193253	J250 9	5.0	15.6	12.7	3.3	1.0	22°	9°
3G6304HD	J300 9	7.6	20.3	11.6	3.3	1.4	22°	8°
8E9490	J300 9	7.7	21.0	14.9	4.0	1.3	23°	12°
9W1304	J300 9	7.6	20.3	11.6	3.3	1.4	22°	8°
1U1350	J350 9	13.8	25.4	17.8	4.6	1.7	22°	14°
3G8354	J350 9	9.1	21.0	12.1	4.3	1.6	35°	8°
6I6354	J350 9	12.2	22.9	18.4	4.6	1.4	22°	12°
6I6404	J400 9	13.3	25.1	19.7	4.8	1.9		
1U1454	J450 9	18.0	26.7	20.3	5.4			
1140464	J460 2	20.8	30.5	20.3	5.4	1.9		
8E3464	J460 2	30.9	31.8	22.9	5.4	1.9	22°	12°
1590464	J460 9	18.0	28.3	18.7	5.4	1.1	24°	9°
1073554	J550 2	34.2	36.8	31.8	6.7	2.5	22°	15°
3G9494	J550 2	30.2	36.2	32.1	6.7	2.7	22°	15°
6I6554	J550 9	28.0	35.6	26.7	6.4	2.5	23°	9°
6I6554	J550 9	34.7	33.7	27.9	6.5	2.7	22°	9°
6I6604	J600 9	56.6	36.8	30.5	7.8	3.5	22°	9°
4T4704	J700 2	72.5	46.0	33.3	7.8	2.5	22°	15°
6I8804	J800 9							

...continued

41122 Modena Italy
via delle Nazioni, 65

ph +39 059 9780111
fax +39 059 9780061
@ info@usco.it

part number are for reference purposes only

www.usco.it



USCO SpA



ITR PRODUCT CATALOGUE

CAT STYLE WELD ON CORNER ADAPTER

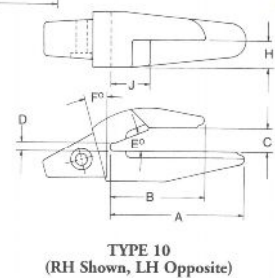
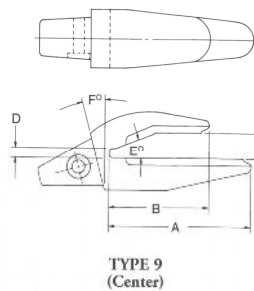
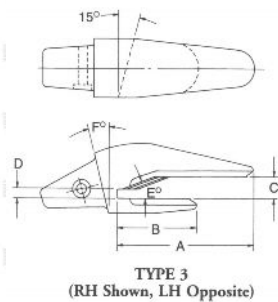

PART NUMBER	FAMILY & TYPE	WEIGHT	A	B	C	D	E	F
3G6306	J300 10L	7.9	20.3	11.6	3.3	1.4	22°	8°
3G6305	J300 10R	7.9	20.3	11.6	3.3	1.4	22°	8°
3G8356	J350 10L	8.8	21.0	12.1	4.3	1.6	35°	8°
3G8355	J350 10R	8.8	21.0	12.1	4.3	1.6	35°	8°
1U1352	J350 9L	10.4	25.4	17.8	4.6	1.7	22°	14°
1U1351	J350 9R	10.4	25.4	17.8	4.6	1.7	22°	14°
6I6406	J400 10L	12.2	24.4	19.4	4.8	1.9		
6I6405	J400 10R	12.2	24.4	19.4	4.8	1.9		
8E2466	J460 10L	20.9	28.3	18.7	5.4	1.1	24°	9°
8E2465	J460 10R	20.9	28.3	18.7	5.4	1.1	24°	9°
1140466	J460 3L	21.2	27.9	20.3	2.7	1.1		
8E3466	J460 3L	21.2	31.8	22.9	5.4	1.9	22°	12°
1140465	J460 3R	21.2	27.9	20.3	2.7	1.1		
8E3465	J460 3R	21.2	31.8	22.9	5.4	1.9	22°	12°
1U1556	J550 10L	17.9	35.6	26.7	6.4	2.5	23°	9°
1U1555	J550 10R	27.9	35.6	26.7	6.4	2.5	23°	9°
1073566	J550 3L	35.2	36.8	31.8	6.7	2.5	22°	15°
3G9496	J550 3L	31.0	38.1	34.0	6.7	2.7	22°	15°
1073555	J550 3R	35.2	36.8	31.8	6.7	2.5	22°	15°
3G9495	J550 3R	31.0	38.1	34.0	6.7	2.7	22°	15°
6I6606	J600 9L	60.0	36.8	30.5	7.8	3.5	22°	9°
6I6605	J600 9R	60.0	36.8	30.5	7.8	3.5	22°	9°

...continued

41122 Modena Italy
via delle Nazioni, 65

ph +39 059 9780111
fax +39 059 9780061
@ info@usco.it

part number are for reference purposes only

www.usco.it



USCO SpA



ITR PRODUCT CATALOGUE



CAT STYLE FLUSH MOUNTED ADAPTERS

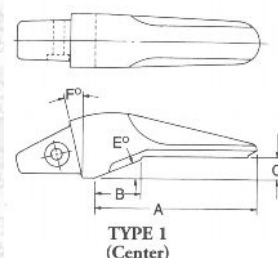

PART NUMBER	FAMILY & TYPE	WEIGHT LBS.	A	B	C	D	E	F
4T1204	J200 1	2.0	18.4	1.3	-1.3		23°	13°
1U1254	J250 1	5.7	23.5	5.1	2.5		22°	13°
1U1304	J300 1	7.2	23.8	5.9	2.7		22°	14°
1U1354	J350 1	14.3	28.6	9.5	3.8		22°	14°

41122 Modena Italy
via delle Nazioni, 65

ph +39 059 9780111
fax +39 059 9780061
@ info@usco.it

part number are for reference purposes only

www.usco.it



ITR PRODUCT CATALOGUE



1 c) Caterpillar Tips and Adapters by Family

	J200	J225	J250	J300	J350	J400	J450/460	J550	J600	J700	
T I P S	Long	1U3202	6Y3222*	1U3252	1U3302	1U3352	7T3402	9W8452	9W8552	6I6602*	4T4702*
	Short		6Y6221*	1U3251	1U3301	1U3351	7T3401	9W8451	9W8551	6I6601*	
	Penetration	1U3209*	6Y8229*	9J4259*	9J4309	9J4359	6Y7409*	9W8459	9W8559*	7I7609*	4T4709*
	Heavy Duty Long		8E4222*	9N4252	9N4302	9N4352	8E4402	9N4452	9N4552	7Y0602	9U9702*
	Standard Pin	8E6208	6Y3228	8E6258	1073308	8E6358	7T3408	8E0468	6Y8558	6I6608*	
	Standard Retainer	8E6209	8E6259	8E6259	8E6259	8E6359	8E8409	8E8469	8E5559	6I6609	
A D A P T E R S	Bolt-on centre	9J4207	6Y6227*	1U0257	1U0307	3G3357	6I9898*	8E2467*			
		8E2184*			4T4307	1700073*					
					3G9307	1U1357					
					3G5307	3G2357*					
					3G1357*						
	Corner adapter (LH)	1U2208*	6Y6228*	3G4258	3G4308	3G5358	8E2469*	8E3469*			
	Corner adapter (RH)	1U2209*	6Y6229*	3G4259	3G4309	3G5359	8E2468*	8E3468*			
	Corner adapter (LH)				3G8308	1U1358*					
	Corner adapter (RH)				3G8309	1U1359*					
	Flushmount- Weld on	4T1204*		1U1254	1U1304	1U1354	1073404*	8E0464	3G4554*		
	2 – Strap Weld on (Centre)							8E3464*	3G9494*	6I8604*	4T4704*
	Bottom Strap W/on (Centre)	8J7525		3G0169*	9J8929*	1U1350		8E5464*	9J3662*		
	2 – Strap Weld on (Centre)	1193204*	6Y3224	9W1304	9W1304	6I6354	6I6404	1590464	3G9494	6I6604	
1193205*			1193253		3G8354		1U1454	6I6554*			
			3G6304	8E9490*							
2 – Strap Weld on (LH)					3G8356						
2 – Strap Weld on (RH)					3G8355						



USCO SpA



ITR PRODUCT CATALOGUE



1 d) Caterpillar Ripper Tips by Machine

TYPICAL MACHINE APPLICATION	D4E, D4H, 963, 12,	D5B, D5H, D6D, D6H,	GRADERS	D8H, D8K, D8L, D8N,	D9G, D9H, D9N, D8R	D9L, D9R SS	D10, D10N, D10R	D11N MS	D11N SS
Centreline Long		6Y0352		1140453	1140453	8E8503	8E8503	8E8503	
Centreline Medium				9W2452	9W2452	4T4502	4T4502	4T4502	9W4552
Centreline Short				9W2451	9W2451	4T4501	4T4501	4T4501	9W4551
Penetration Long	6Y0309	6Y0359				4T5503	4T5503	4T5503	
Penetration Medium				4T5452	4T5452	4T5502	4T5502	4T5502	6Y3552
Penetration Short				4T5451	4T5451	4T5501	4T5501	4T5501	
Sharp	9W7309								
Scarifier Tip			6Y5230 (2D5572)						
PIN									
Standard Pin	9W2668		N/A						
Standard Retainer	1U2405								
Standard Duty Pin	1368308	1140358							
Retainer for HD Pin	1U2405	1140359							
SHANK PROTECTORS									
Standard				6J8814	6J8814				
Sharp				8E1848	8E1848	9W8365	9W8365	6Y8960	9N4621
Shank Adapter				8E8418	8E8418	1038115	1U3630		

41122 Modena Italy
via delle Nazioni, 65

ph +39 059 9780111
fax +39 059 9780061
@ info@usco.it

part number are for reference purposes only

www.usco.it



USCO SpA



ITR PRODUCT CATALOGUE



1 e) Komatsu Bucket and Ripper Tips

PART NUMBER	DESCRIPTION	ALTERNATIVE NOS.	APPLICATIONS
205-70-19570	Tip, Horizontal Pin		PC100/120/200, PC210/200/240
207-70-14151	Tip, Horizontal Pin		PC220/300/310/350
205-70-74272	Tip, Vertical Pin		PC100/150/200/220/240/280/300
208-70-14152	Tip, Horizontal Pin	208-70-14151	PC400, PC450
207-70-14280	Tip, Horiz Pin – Long Life		PC 220/300/310/350
423-70-13114	Tip, Bolt On		WA380/400/420/450/470
141-78-11253	Tip, Ripper		D60, D65, D70
175-78-31230	Tip, Ripper		D85, D155
195-78-21331	Tip, Ripper		D275, D355
195-78-71140	Tip, Ripper		D375
195-78-71320	Tip, Ripper		D375

41122 Modena Italy
via delle Nazioni, 65

ph +39 059 9780111
fax +39 059 9780061
@ info@usco.it

part number are for reference purposes only

www.usco.it



USCO SpA



ITR PRODUCT CATALOGUE



1 f) Komatsu Tips and Adapters by Machine

TYPICAL MACHINE APPLICATIONS	WA180-1/3	WA250-1/3 WA320-1/3	WA380-1/3 WA400-1 WA420-1/3 WA450-1/3 WA470-1/3	WA500-1/3	WA600-1/3	WA700-1	PC100-5/6 PC120-5/6 PC200-5/6 PC210-5/6	PC220-5/6	PC300-5/6	PC400-5/6	PC650-5
1) Bolt-On Teeth											
Bolt-On Centre	418-70-13150	419-70-13114	423-70-13114	425-70-13212	426-70-13311						
Bolt-On RH	418-70-13160	419-70-13164	423-70-13144	425-70-13222	426-70-13321						
Bolt On LH	418-70-13170	419-70-13174	423-70-13154	425-70-13232	426-70-13331						
2) Horizontal Pin Teeth											
Standard Horiz Pin	20X-70-14160	202-70-12130	423-847-1140	426-847-1110	426-847-1110	427-70-13731	205-70-19570	206-70-48610	207-70-14151	208-70-14152	209-70-54210
Long Life Horiz Pin							205-70-68260	*207-70-14280	207-70-14280		
Pin – Horiz	20X-70-00100	09244-02496	09244-02516	426-847-1130	426-847-1130	427-70-13770	09244-02496	09244-02496	09244-02516	09244-03036	209-70-54240
				09244-03036	09244-03036			*09244-02516			

...continued



USCO SpA



ITR PRODUCT CATALOGUE



TYPICAL MACHINE APPLICATIONS	WA180-1/3	WA250-1/3 WA320-1/3	WA380-1/3 WA400-1 WA420-1/3 WA450-1/3 WA470-1/3	WA500-1/3	WA600-1/3	WA700-1	PC100-5/6 PC120-5/6 PC200-5/6 PC210-5/6	PC220-5/6	PC300-5/6	PC400-5/6	PC650-5
3) Vertical Pin Teeth											
Vertical Pin Teeth							205-70-74272	206-70-54221	207-70-34212	208-70-34211	209-72-14150
Pin, Lock - Vertical							205-70-74281	205-70-74281	207-70-34221	208-70-34220	209-72-14160
Retainer - Vertical							205-70-74291	205-70-74291	205-70-74291	208-70-34191	209-72-14170
Side Cutter							205-70-74180	205-70-74180	207-70-34160	208-70-34160	209-70-14181
Side Cutter							205-70-74190	205-70-74190	207-70-34170	208-70-34170	209-70-14191
4) Bolt-On Adapters											
Bolt-On Centre	418-847-1120	419-847-1111	423-847-1111	425-847-1191	425-847-1191						
Bolt-On RH	418-847-1160	419-847-1121	423-847-1121	425-847-1211	425-847-1211						
Bolt-On LH	418-847-1170	419-847-1131	423-847-1131	425-847-1221	425-847-1221						
5) Weld-On Adapters (Horizontal Pin)											
Weld-On Centre		419-847-1210	423-847-1210	426-847-1121	426-847-1121	427-70-13743	20Y-70-14520	206-70-58520	207-939-3120	208-939-3120	209-70-54143
Weld-On RH		419-847-1220	423-847-1230	426-848-1121	425-847-1151	427-70-13754	205-939-7120	206-939-5120			
Weld-On LH		419-847-1230	423-847-1220	426-848-1131	425-845-1161	427-70-13764					
6) Weld-On Adapters (Vertical Pin)											
Weld-On Centre							203-70-64210	206-70-58150	207-70-34151	208-70-34150	209-944-1220



USCO SpA



ITR PRODUCT CATALOGUE

1 g) Komatsu Ripper Tips by Machine

TYPICAL MACHINE APPLICATIONS	D40, D41, D45, D53, D57	D60, D65	D85, D135, D155	D275, D355	D375-1, 2	GD600 GD700	GD500	NOTES
Standard	131-78-31190	141-78-11253						
Symmetric, Standard B-Type			175-78-31230	195-78-21331	195-78-71320			D375-1/2
Long, Non Sym. C-type			175-78-61660	195-78-29130	195-78-71370			
Long, Non Sym. D-type			175-78-34141	195-78-71370	195-78-71450			
Symmetric, Short E-Type HD			175-78-31232	195-78-21333	195-78-71390			
					195-78-71140*			* D375-1
Standard Pin	09244-02496	09244-02508	09244-02508	09244-02508	195-78-71360# 09244-02508*	113-78-21170		#30mm Dia *25mm Dia
SHANK PROTECTORS:								
Standard			195-78-21320	195-78-21320	195-78-71111			
Extended (With Lip)			195-78-21580	195-78-21580	195-78-72410			
			154-78-31330#	17M-78-21330				#D85
Shank Adapter (Nose piece)		154-78-14340	195-78-14350	198-79-11620	195-78-71380			
		2 - Pin	3 - Pin	3 - Pin	3 - Pin			
		175-78-21610						
		3 - Pin						
Retainer Pin – Protector			09244-02508	09244-02508	195-78-71360			
Ripper Tip						234-785-1121		
Ripper Shank						232-785-1291		
Scarifier Tip - Graders						232-71-51320	232-71-51320	
Scarifier Shank (Tip Type)						232-71-51310	232-71-51310	
Scarifier Shank (No Tip)							232-70-13130	

41122 Modena Italy
via delle Nazioni, 65

ph +39 059 9780111
fax +39 059 9780061
@ info@usco.it

part number are for reference purposes only

www.usco.it



USCO SpA



ITR PRODUCT CATALOGUE

ITR BOFORS TEETH AND ADAPTERS

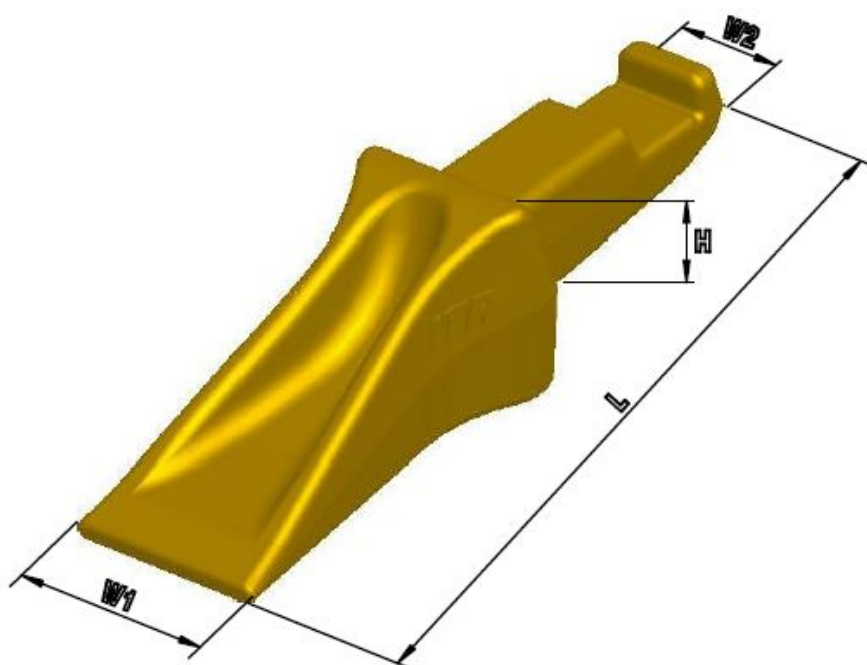

**The highest technical specifications
to guarantee the maximum wear life**

BOFORS TEETH ANALYSIS %

C	Mn	Si	Cr	Ni	Mo	P	S	Al
0.25~0.31	0.50~0.75	1.40~1.70	1.80~2.00	0.15~0.30	0.30~0.40	<0.035	<0.035	<0.035

41122 Modena Italy
via delle Nazioni, 65

ph +39 059 9780111
fax +39 059 9780061
@ info@usco.it

part number are for reference purposes only

www.usco.it



USCO SpA



ITR PRODUCT CATALOGUE

1 h) Bofors Teeth and Adapters

BOFORS:TEETH							
PART NUMBER	DESCRIPTION	ALTERNATIVE NOS.	DIMENSION				
			L	H	W1	W2	KG
3027512	TOOTH	38101, 71-110	585	75	105	75	24
3027524	TOOTH	38102, 71-114	590	75	150	75	32
3027538	TOOTH	71-112	510	64	120	64	21
3027689	TOOTH	38104, 71-108	510	64	95	64	16
3027705	TOOTH	3031539, 33102, 71-143	422	59	110	59	11,7
3031197	TOOTH	3031542, 71-144, 34102	525	70	126	47	22
3031334	TOOTH	33101, 71-124	485	58	100	56	14
3031335	TOOTH	34101, 71-126	546	64	110	63	20,5
3031336	TOOTH	35101, 71-128	596	75	125	74	29
3031354	TOOTH	33104, 71-163	400	59	110	59	11,2
3031362	TOOTH	71-172	400	54	85	54	6
3031364	TOOTH	33103, 71-125	503	58		56	12,5
3031365	TOOTH	71-127	558	64		63	19
3031366	TOOTH	71-129	623	75		74	27
3031386	TOOTH	35102, 71-145	660	80	150	100	38
3031537	TOOTH/FOR VOLVO 440D	32101, 71-142	377	49	86	49	8,2
3032682	TOOTH	32105, 71-162	345	54	80	50	7,1
4037988	TOOTH	71-101	346	45	76	45	5
4038205	TOOTH		450	58	92	57	10
4038207	TOOTH		485	58	92	57	12
4038257	TOOTH	71-106	450	58	92	57	10
4038261	TOOTH	38111, 71-105	485	58	92	57	12
4044291	TOOTH	30103, 71-170	228	36	61	36	2,1
4044336	TOOTH	31101, 71-120	340	44	80	42	6
4044388	TOOTH	31103, 71-171	310	44	65	42	3,3
4044428	TOOTH	32102, 71-122	408	53	90	50	9,7
4046663	TOOTH	71-104	405	58	90	57	10
4046729	TOOTH	71-102	354	48	79	48	7,3
4046746	TOOTH	71-107	460	58		57	11
4046796	TOOTH	31102, 4047167, 71-141	312	38	71	38	4,5
4046799	TOOTH	31104, 71-161	282	38	66	38	3,7
4046815	TOOTH	30101, 4047166, 71-140	260	36	61	36	2,5

...continued

41122 Modena Italy
via delle Nazioni, 65

ph +39 059 9780111
fax +39 059 9780061
@ info@usco.it

part number are for reference purposes only

www.usco.it



USCO SpA



ITR PRODUCT CATALOGUE



BOFORS: TEETH

PART NUMBER	DESCRIPTION	ALTERNATIVE NOS.	DIMENSION				
			L	H	W1	W2	KG
4046818	TOOTH	30104, 71-160					
4046911	TOOTH	32103, 71-123	425	53		50	8,7
4046961	TOOTH	71-164	310	44	80	42	3,9
71-103	TOOTH		404	50		50	7
71-109	TOOTH		550	64		64	16
71-111	TOOTH		630	75		75	24
71-121	TOOTH		380	44		44	6

BOFORS: ADAPTERS

PART NUMBER	DESCRIPTION	ALTERNATIVE NOS.	DIMENSIONS			
			L	H	W1	KG
3031112	ADAPTER	71-204	240	116	116	11
3031387	ADAPTER	35003, 71-245	300	123	167	18,5
3031394	ADAPTER	32003, 71-222	230	105	115	9,5
3031395	ADAPTER	33003, 71-224	270	110	123	12,5
3031396	ADAPTER	34003, 71-226	300	125	140	18
3031397	ADAPTER	71-228	320	144	155	27
3031434	ADAPTER	31003, 71-220	195	95	100	7
4044339	ADAPTER	34004, 71-244				
4046797	ADAPTER	31004, 71-241	160	61	75	1,9
4046816	ADAPTER	31006, 71-240	120	50	63	1
4046819	ADAPTER	32004, 71-242	205	74	93	3,8
4046862	ADAPTER	33004, 71-243	214	83	105	5,1
71-201	ADAPTER		200	80	90	5,5
71-202	ADAPTER		220	82	106	7
71-208	ADAPTER		300	116	134	17
71-210	ADAPTER		330	121	145	22

41122 Modena Italy
via delle Nazioni, 65

ph +39 059 9780111
fax +39 059 9780061
@ info@usco.it

part number are for reference purposes only

www.usco.it



USCO SpA



ITR PRODUCT CATALOGUE

ITR PINS & RETAINERS



**The highest technical specifications
to guarantee the longest life**

41122 Modena Italy
via delle Nazioni, 65

ph +39 059 9780111
fax +39 059 9780061
@ info@usco.it

part number are for reference purposes only

www.usco.it



USCO SpA



ITR PRODUCT CATALOGUE

1 i) Pins & Retainers



CATERPILLAR PINS & RETAINERS

PART NUMBER	DESCR.	OLD NUMBER	DIAMETER	LENGTH
1029062	PIN - LOCK	3G0500	31.75	153
1073308	PIN - LOCK		14	92
1073378	PIN - LOCK HD		25	162
1073469	RETAINER HD		44	
1078559	RETAINER HD		53	
1139608	PIN - LOCK HD	6I6608	30	195
1139609	RETAINER HD	6I6609	59	
1140358	PIN - LOCK HD		19	108
1140359	RETAINER HD			
1140468	PIN - LOCK HD		24	135
1167408	PIN - LOCK HD		22	119
1167409	RETAINER HD		42	
1324762	PIN - LOCK HD		14	69
1324763	PIN - LOCK HD	8E6258	14	81
1324766	PIN - LOCK HD		14	92
1495733	REATER HD	1330699	30	
1U1558	PIN - LOCK	7J9558		
1U2405	RETAINER		38	
2K6413	PIN - LOCK			
3G9549	RETAINER	7J6845		
3G9559	RETAINER			
3G9609	RETAINER	8A7865		
4T0001	RETAINER			
4T1458	PIN - LOCK		19	135
4T2479	PIN - LOCK	7J9600	25.4	128
4T4707	RETAINER		64	
6J8811	PIN - LOCK		31.75	115
6Y1202	RETAINER		64	
6Y1204	PIN - LOCK		31.75	153

...continued

41122 Modena Italy
via delle Nazioni, 65

ph +39 059 9780111
fax +39 059 9780061
@ info@usco.it

part number are for reference purposes only

www.usco.it



USCO SpA



ITR PRODUCT CATALOGUE

PART NUMBER	DESCR.	APPLIC.	DIAMETER	LENGTH
6Y2527	PIN - LOCK	9J4458, 8J1458, 9W2688, 9W8296, 1U1458		
6Y3228	PIN - LOCK		14	69
6Y3394	PIN - LOCK		25.4	128
6Y3909	PIN - LOCK HD		31.75	153
6Y8558	PIN - LOCK		25	162
6Y9459	RETAINER			
7T3408	PIN - LOCK		22	119
8E0468	PIN - LOCK		24	141
8E4743	RETAINER		48	
8E5559	RETAINER		53	
8E6208	PIN - LOCK		11	60
8E6209	RETAINER		19	
8E6259	RETAINER		29	
8E6359	RETAINER		40	
8E8409	RETAINER		42	
8E8469	RETAINER		44	
8J5309	RETAINER			
9J2258	PIN - LOCK			
9W2668	PIN - LOCK	9J6583	19	88
9W2678	PIN - LOCK	8E6358	19	108
9W9026	PIN - LOCK			

KOMATSU PINS & RETAINERS

PART NUMBER	DESCR.	APPLIC.	DIAMETER	LENGTH
09244.03036	PIN - LOCK	WA500-1, WA600-1, PC400, D375A-2	25	145
09244.02516	PIN - LOCK	PC220, PC240, PC300, WA400, WA 420, WA470	25	119
09244.02508	PIN - LOCK	D65, D155, D275, D355	25	109
09244.02496	PIN - LOCK	D41, D50, PC100, PC200, WA300, WA320	25	97
195.78.71360	PIN - LOCK	D375A-1, D375A-2	30	113
209.70.54240	PIN - LOCK	PC650, PC750	36	165

41122 Modena Italy
via delle Nazioni, 65

ph +39 059 9780111
fax +39 059 9780061
@ info@usco.it

part number are for reference purposes only

www.usco.it



USCO SpA



ITR PRODUCT CATALOGUE

ITR FORK TEETH

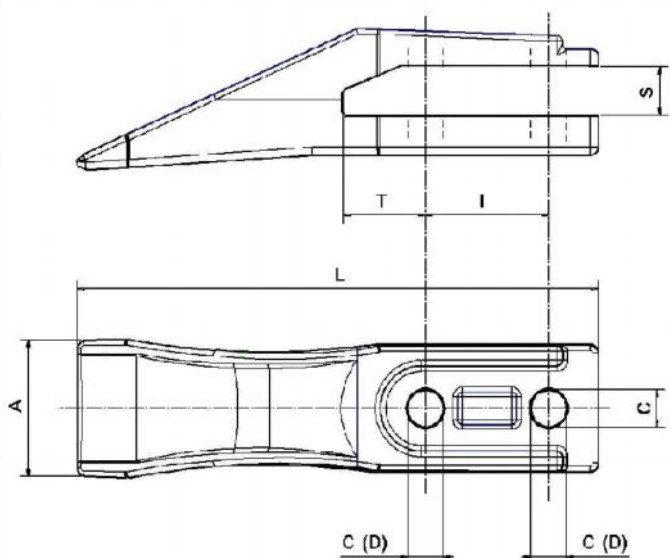

**The highest technical specifications
to guarantee the maximum wear life**

41122 Modena Italy
via delle Nazioni, 65

ph +39 059 9780111
fax +39 059 9780061
@ info@usco.it

part number are for reference purposes only

www.usco.it



USCO SpA



ITR PRODUCT CATALOGUE

1 l) Fork Teeth



FORK TEETH

PART NUMBER	ALTERNATIVE NOS	WEIGHT [KG]	DIMENSIONS [MM]						
			L	A	T	I	S	C	D
UE190H37	E11.1 D1000FU	1,3	190	50	37	45	17	13	-
UE190H37D	E11.4 D1000.3FU	1,3	190	50	37	40-45	17	13	18
UE190L18	E11.8 D1000.9FU	1,3	190	50	18	55	13	13	-
UE190H30D	E11.10	1,3	190	50	30	22,5	17	13	20
UE190HH37D	E12.4	1,2	190	40	37	45	18	13	18
UE222L48	E20.1 D180.1FU	1,7	222	53	48	50	17	15	-
UE222H48	E20.2 D180.2FU	1,7	222	53	48	50	22	15	-
UE222L37	E20.3 D180.7	1,7	222	53	37	45	17	13	-
UE222H37	E20.4 D180.8FU	1,7	222	53	37	45	22	13	-
UE222L51	E20.5 D180.18	1,7	222	53	51	60	17	13	-
UE222H54	E20.6	1,7	222	53	54	45	22	15	-
UE222L36	E20.7 D180.6FU	1,7	222	53	36	55	17	16	-
UE222L46	E20.8	1,7	222	53	46	50	17	10.5	-
UE222H45	E20.9	1,7	222	53	45	60	22	13	-
UE222H42	E20.10 D180.3	1,7	222	53	42	55	22	16	-
UE222H46	E20.11	1,7	222	53	46	55	22	16	-
UE222H46S	E20.12	1,7	222	53	46,5	60	22	16	-

...continued

41122 Modena Italy
via delle Nazioni, 65

ph +39 059 9780111
fax +39 059 9780061
@ info@usco.it

part number are for reference purposes only

www.usco.it

35



USCO SpA



ITR PRODUCT CATALOGUE



FORK TEETH

PART NUMBER	ALTERNATIVE NOS	WEIGHT [KG]	DIMENSIONS [MM]						
			L	A	T	I	S	C	D
UE222H61	E20.13 D180.9FU	1,7	222	53	61	45	22	13	-
UE275H66	E30.1 D10.1FU	2,6	275	61	66	65	22	13	-
UE275H67	E30.2	2,6	275	61	67	65	22	15	-
UE275H51	E30.3 D16FAIFU	2,6	275	61	51	80	22	15	-
UE275H56	E30.4 D300.10	2,6	275	61	56	65	22	13	-
UE275H50	E30.5	2,6	275	61	50	85	22	17	-
UE275H62	E30.6 D130.10FU	2,6	275	61	62	45	22	15	-
UE275H61	E30.7	2,6	275	61	61	65	22	17	-
UE275H47	E30.8	2,6	275	61	47	90	22	13	-
UE275H72	E30.9	2,6	275	61	72	72	22	18	-
UE275H49	E30.10	2,6	275	61	49	70	22	15	-
UE300H70	E40.1 D60.20 FU	3.3	300	66	70	70	27	17	-
UE300H53	E40.2 D130.20FU	3.3	300	66	53	64	27	15	-
UE300H60	E40.3	3.3	300	66	60	70	27	17	-
UE300H55	E40.4	3.3	300	66	55	85	27	15	-
UE300L62	E40.5	3.3	300	66	62	85	22	14,5	-
531.03205	E25	2.5	250	54	51	44,5	22	20,5	-
531.03208	E25 R	5.0	260	50	51	44,5	22	20,5	-
531.03209	E25 L	5.0	260	50	51	44,5	22	20,5	-
522.00102	E3	1.0	184	50	40	40	15	13	-

41122 Modena Italy
via delle Nazioni, 65

ph +39 059 9780111
fax +39 059 9780061
@ info@usco.it

part number are for reference purposes only

www.usco.it



USCO SpA



ITR PRODUCT CATALOGUE



G.E.T. CATALOGUE CATALOGO PARTI USURA

2) *CUTTING EDGES*

a) *ITR Profiles*

b) *Caterpillar Cutting Edges*

c) *Komatsu Cutting Edges*

41122 Modena Italy
via delle Nazioni, 65

ph +39 059 9780111
fax +39 059 9780061
@ info@usco.it

part number are for reference purposes only

www.usco.it



USCO SpA



ITR PRODUCT CATALOGUE

ITR PROFILES

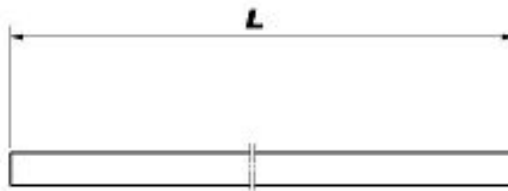
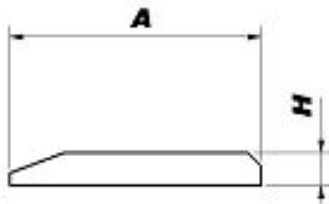
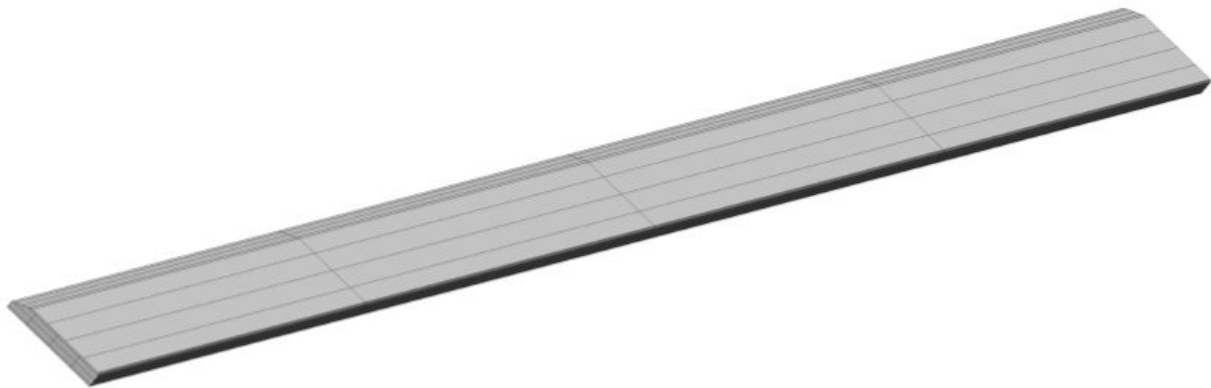

The highest technical specifications to guarantee the maximum wear life

ITR PROFILES HARDNESS	
EN250 STEEL	250 HB MIN
ET400 STEEL	400 HB MIN

41122 Modena Italy
via delle Nazioni, 65

ph +39 059 9780111
fax +39 059 9780061
@ info@usco.it

part number are for reference purposes only

www.usco.it



USCO SpA



ITR PRODUCT CATALOGUE

2 a) ITR Profiles



HARDNESS : HB 250

PART NUMBER	DESCR.	HARDNESS [HB]	KG.	DIMENSIONS[MM]		
				A	H	L
UE11163000H25	SINGLE BEVEL PROFILE	250	40,5	110	16	3000
UE15163000H25	SINGLE BEVEL PROFILE	250	55,2	150	16	3000
UE15166000H25	SINGLE BEVEL PROFILE	250	110,4	150	16	6000
UE15203000H25	SINGLE BEVEL PROFILE	250	65,4	150	20	3000
UE20203000H25	SINGLE BEVEL PROFILE	250	82,6	200	20	3000
UE20206000H25	SINGLE BEVEL PROFILE	250	177,6	200	20	6000
UE20253000H25	SINGLE BEVEL PROFILE	250	116	200	25	3000
UE25253000H25	SINGLE BEVEL PROFILE	250	137,4	250	25	3000
UE30253000H25	SINGLE BEVEL PROFILE	250	167,1	300	25	3000
UE30303000H25	SINGLE BEVEL PROFILE	250	199	300	30	3000
UE30351250H25	SINGLE BEVEL PROFILE	250	-	300	35	1250
UE30401250H25	SINGLE BEVEL PROFILE	250	-	300	40	1250
UE30401400H25	SINGLE BEVEL PROFILE	250	-	300	40	1400
UE30401500H25	SINGLE BEVEL PROFILE	250	-	300	40	1500
UE30401600H25	SINGLE BEVEL PROFILE	250	-	300	40	1600
UE30401800H25	SINGLE BEVEL PROFILE	250	-	300	40	1800
UE36301450H25	SINGLE BEVEL PROFILE	250	-	360	30	1450
UE36301600H25	SINGLE BEVEL PROFILE	250	-	360	30	1600
UE406351450H25	SINGLE BEVEL PROFILE	250	-	406	35	1450
UE406351600H25	SINGLE BEVEL PROFILE	250	-	406	35	1600

41122 Modena Italy
via delle Nazioni, 65

ph +39 059 9780111
fax +39 059 9780061
@ info@usco.it

part number are for reference purposes only

www.usco.it



USCO SpA



ITR PRODUCT CATALOGUE



HARDNESS: HB 400

PART NUMBER	DESCR.	HARDNESS [HB]	KG.	DIMENSIONS [MM]		
				A	H	L
UE11163000H40	SINGLE BEVEL PROFILE	400	40,5	110	16	3000
UE15203000H40	SINGLE BEVEL PROFILE	400	65,4	150	20	3000
UE20203000H40	SINGLE BEVEL PROFILE	400	82,6	200	20	3000
UE20253000H40	SINGLE BEVEL PROFILE	400		200	25	3000
UE25253000H40	SINGLE BEVEL PROFILE	400	137,4	250	25	3000
UE25253000H40	SINGLE BEVEL PROFILE	400		250	30	3000
UE30253000H40	SINGLE BEVEL PROFILE	400	167,1	300	25	3000
UE30303000H40	SINGLE BEVEL PROFILE	400	199	300	30	3000
UE30351250H40	SINGLE BEVEL PROFILE	400	-	300	35	1250
UE30401250H40	SINGLE BEVEL PROFILE	400	-	300	40	1250
UE30401400H40	SINGLE BEVEL PROFILE	400	-	300	40	1400
UE30401500H40	SINGLE BEVEL PROFILE	400	-	300	40	1500
UE30401600H40	SINGLE BEVEL PROFILE	400	-	300	40	1600
UE30401800H40	SINGLE BEVEL PROFILE	400	-	300	40	1800
UE36301450H40	SINGLE BEVEL PROFILE	400	-	360	30	1450
UE36301600H40	SINGLE BEVEL PROFILE	400	-	360	30	1600
UE406351450H40	SINGLE BEVEL PROFILE	400	-	406	35	1450
UE406351600H40	SINGLE BEVEL PROFILE	400	-	406	35	1600
UE25253000H45	SINGLE BEVEL PROFILE	450	137.4	250	25	3000
UE30253000H45	SINGLE BEVEL PROFILE	450	167.1	300	25	3000

41122 Modena Italy
via delle Nazioni, 65

ph +39 059 9780111
fax +39 059 9780061
@ info@usco.it

part number are for reference purposes only

www.usco.it



USCO SpA



ITR PRODUCT CATALOGUE

ITR BORON STEEL CUTTING EDGES



The highest technical specifications to guarantee the maximum wear life

ELEMENT	CUTTING EDGE %
Carbon	0,31
Silicon	0,25
Manganese	1,1 to 1,4
Phosphorus	0,030 max
Sulphur	0,030 max
Chromium	0,25

ELEMENT	CUTTING EDGE %
Molybdenum	0,06
Nickel	0,30 max
Copper	0,40 max
Tin	0,03 to 0,05
Titanium	0,03 to 0,05
Boron	0,001 to 0,004

CUTTING EDGE CHEMICAL COMPOSITION
31MnCrB5H

CUTTING EDGE HARDNESS	
<u>SURFACE</u>	415 to 514 HB.
<u>CENTRE</u>	370 HB minimum

Chemical composition in % . HB - Hardness Brinell / HRc - Hardness Rockwell c.

41122 Modena Italy ph +39 059 9780111
 via delle Nazioni, 65 fax +39 059 9780061
 @ info@usco.it

part number are for reference purposes only
www.usco.it



ITR PRODUCT CATALOGUE

2 b) Caterpillar Cutting Edges

PART NUMBER	DESCR.	ALT NOS.	APPLIC.	KG.	THICKNESS	BOLT	N°	NUT	N°
1U0292	Cutting Edge		936	55	25	1J5607	3	2J3507	3
1U0295	Bolt-On Edge		916, 926, 953	49	25	1J5607	3	2J3507	3
1U0593	Cutting Edge		943, 953	107	30	5P8823	12	3K9770	12
1U0601	Cutting Edge		950, 960, 966	90	30	4F4042	3	2J3507	3
1U0761	Cutting Edge		980, 988	43	40	5P8823	3	3K9770	3
1U0762	Cutting Edge		980	148	35	5P8823	3	3K9770	3
1U1464	Bolt-On Edge		920, 930, 950	39	25	1J5607	3	2J3507	3
1U1465	Cutting Edge		920, 930, 950	37	25	1J5607	3	2J3507	3
1U1475	Cutting Edge		966	55	30	4F4042	4	2J3507	4
1U1476	Cutting Edge		966	103	30	4F4042	8	2J3507	4
1U1909	Cutting Edge		966, 970	93	30	5P8823	3	3K9770	3
1U2352	Cutting Edge	4T2914	910, 931	15	19	4F7827	7	2J3506	7
1U2406	Cutting Edge		966	91	30	6V6535	3	3K9770	3
1U2412	Bolt-On Edge		950	55	30	4F4042	3	2J3507	3
1U4929	Cutting Edge		D8	36	25	4F4042	6	2J3507	6
1U4930	Cutting Edge		D8	39	25	4J9208	6	2J3507	6
1U4941	Cutting Edge		D5,D6	88	35	4J9058	7	2J3507	7
3G4282	Cutting Edge		D5,D6	32	19	5J4773	7	2J3506	7
3G6062	Cutting Edge		D5, D6	29	19	5J4773	7	2J3506	7
3G9306	Cutting Edge		D4, D5	20	16	5J4771	6	2J3506	6
4T0731	Cutting Edge		D5	23	19	5J4773	5	2J3506	5
4T2315	Cutting Edge		D5, D6	43	19	5J4773	10	2J3506	10
4T2334	Cutting Edge	7J2980		104	41	8J2928	7	2J3507	7
4T2887	Cutting Edge		470, 491, 630	112	25	4F4042	10	2J3507	10
4T2888	Cutting Edge	5J6852	D8	74	25	1J6762	16	2J3506	16
4T2899	Cutting Edge		633, 639	71	29	4J9208		2J3507	
4T2900	Cutting Edge		630	113	29	7J3026	9	7J2957	9
4T2921	Cutting Edge	7J2363	D7, 814	36	19	4T2921	7	2J3505	7
4T2922	Cutting Edge		D7, 814, 816	26	19	5J4772	5	2J3505	5
4T2923	Cutting Edge		814, 816	35	19	5J2409	7	2J3505	7
4T2944	Cutting Edge		D8	45	19	1J6762	13	2J3506	13
4T2945	Cutting Edge		D7	24	19	5J4773	5	2J3506	5
4T2946	Cutting Edge		D7	38	19	5J4773	7	2J3506	7
4T2948	Cutting Edge	5J6888 2C2744 2J5603 2Y1103	D7	37	19	5J4771	7	2J3506	7
4T2949	Cutting Edge		D7	52	19	5J4771	15	2J3506	15
4T2952	Cutting Edge	5J6839	D7, D6	29	19	5J4773	5	2J3506	5
4T2973	Cutting Edge	8J1490	D4	20	16	4F3654	6	4K0367	6

...continued



USCO SpA



ITR PRODUCT CATALOGUE

PART NUMBER	DESCR.	ALT NOS.	APPLIC.	KG.	THICK NESS	BOLT	N°	NUT	N°
4T2974	Cutting Edge	8J1489	D4	19	16	4F3654	5	4K0367	5
4T2985	Cutting Edge	5J6812	D6, D7	38	25	5J4773	5	2J3506	5
4T2986	Cutting Edge		D8, 980	35	25	4J9058	5	2J3507	5
4T2987	Cutting Edge	8J9565 1C6555	D8	42	25	4J9058	6	2J3507	6
4T2988	Cutting Edge	8J8118	D8	49	25	4J9058	7	2J3507	7
4T2989	Cutting Edge	5J6849	D7	49	25	5J4771	7	2J3506	7
4T2991	Cutting Edge		D7	32	25	5J4773	5	2J3506	5
4T2992	Cutting Edge	7J2847	D7, 814	35	25	5J4772	5	2J3505	5
4T2993	Cutting Edge	7J9481	D7, 814	49	25	5J4772	7	2J3505	7
4T2994	Cutting Edge		D8	55	25	4J9058	8	2J3507	8
4T3008	Cutting Edge		D5, D6, 815	32	19	3F5108	11	4K0367	11
4T3009	Cutting Edge		D6	42	19	4F7827	10	2J3506	10
4T3010	Cutting Edge	7J9478	D6	18	19	4F7827	4	2J3506	4
4T3011	Cutting Edge	8J7156	D6	45	19	4F7827	11	2J3506	11
4T3012	Cutting Edge		815	41	19	5J4773	10	2J3506	10
4T3013	Cutting Edge	7J9477	D5, D6	28	19	5J4773	7	2J3506	7
4T3020	Cutting Edge	7J9476	D5, D6, 815	23	19	3F5108	9	4K0367	9
4T3417	Cutting Edge		D8	36	25	4J9208	5	2J3507	5
4T3418	Cutting Edge	6J7116	D8	70	25	5J2409	10	2J3505	10
4T3420	Cutting Edge		D7	37	25	5J4772	5	2J3505	10
4T3421	Cutting Edge		D7	61	25	5J4772	9	2J3505	9
4T3423	Cutting Edge	9J9606	D8	39	25	4J9208	6	2J3507	6
4T3444	Cutting Edge	9J5901	D7	130	28	4F4042	20	2J3507	20
4T5318	Cutting Edge		D7	31	19	6F0196	6	2J3505	6
4T6230	Cutting Edge		D3, D4	16	16	3F5108	6	4K0367	6
4T6232	Cutting Edge		D3, D4	22	16	3F5108	8	4K0367	8
4T6378	Cutting Edge	6J5945 1C6143 5J0337 5J6877 5J6882	D9, D8, 844, 641-UP	62	29	4J9058	6	2J3507	6
4T6379	Cutting Edge		D9	39	29	4J9058	4	2J3507	4
4T6381	Cutting Edge	3G9264		93	29	4F4042	9	2J3507	9
4T6383	Plate Water	9J4444	988	71	29	4J9058	4	2J3507	4
4T6385	Cutting Edge	3G7762	D9	82	29	4J9208	8	2J3507	8
4T6386	Cutting Edge	6J2084	D9, 844	71	29	8J2928	7	2J3507	7
4T6388	Cutting Edge		D9	73	29	8J2928	7	2J3507	7
4T6448	Cutting Edge	5J6803	D9, 824	84	25	4J9208	10	2J3507	10
4T6531	Cutting Edge	5J6831	D8, 824, 825, 834	70	25	5J2409	10	2J3505	10

...continued

41122 Modena Italy
via delle Nazioni, 65

ph +39 059 9780111
fax +39 059 9780061
@ info@usco.it

part number are for reference purposes only

www.usco.it



ITR PRODUCT CATALOGUE

PART NUMBER	DESCR.	ALT NOS.	APPLIC.	KG.	THICKNESS	BOLT	N°	NUT	N°
4T6532	Cutting Edge	5J6833	D8, 816, 824, 825, 834	42	25	5J2409	6	2J3505	6
4T6566 HD	Cutting Edge		631, 637	116	25	4F4042	10	2J3507	10
4T6568 HD	Cutting Edge	5J6845	621, 627	105	25	3J2801	9	2J3507	9
4T6612	Cutting Edge	5J6846 7J3193 8F0923 1H3052 2Y2297 6F3809	20, 90	45	25	4F4042	5	2J3507	5
4T6613 HD	Cutting Edge		613	33	25	4F7827	4	2J3506	4
4T6614 HD	Cutting Edge	7J3025	630, 631	54	25	4J9058	6	2J3507	6
4T6659	Cutting Edge		D6, D5, D4	29	19	5J4773	7	2J3506	7
4T6694	Segment		916, 920, 924, 926, 930	10	25	4F4042	2	2J3507	2
4T6695	Cutting Edge		936, 938, 950	12	25	4F4042	2	2J3507	2
4T6699	Cutting Edge		966, 970, 972	19	30	5P8823	2	2J3507	2
4T9560	Cutting Edge	9W4508		120	41	4J9208	8	2J3507	8
4T9561	Cutting Edge	7J2980		104	41	8J2928	7	2J3507	7
4T9586	Cutting Edge		D8	116	29	4J9058	11	2J3507	11
4T9587	Cutting Edge	6Y5540	D8	57	29	4J9058	5	2J3507	5
4T9838	Cutting Edge			66	35	4J9058		2J3507	
5G2809	Cutting Edge	6S6500	910, 931, 935	60	20	4F7827	7	2J3506	7
5G3085	Cutting Edge		910, 931, 935	62	20	4F7827	7	2J3506	7
5J6873	Cutting Edge	2J0469		59	16				
5V4696	Cutting Edge		950	169	32	4F4042	12	2J3507	12
5V7423	Cutting Edge		920, 930, 944, 950, 953	108	25				
5V7437	Cutting Edge	8K7524	955	100	25	1J5607		2J3507	
6J0256	Cutting Edge			38	19				
6J5340	Cutting Edge			26	19				
6W2984	Cutting Edge	5V4661	920, 930	106	25	1J5607	10	2J3507	10
6W2985	Cutting Edge	6W2988 5V7275 8V1825 8V7619	936	116	25	1J5607	10	2J3507	10
6W2986	Cutting Edge	5V7277	950	106	25	1J5607	9	2J3507	9
6W2987	Cutting Edge	5V7276	950	115	25	4F4042	12	2J3507	12
6W2989	Cutting Edge		966	171	32	6V6535	12	3K9770	12
6W2990	Cutting Edge	7V0904	966	172	32	6V6535	12	3K9770	12
6Y0016	Cutting Edge		D10	105	35	5P8823	9	3K9770	9

...continued



USCO SpA



ITR PRODUCT CATALOGUE

PART NUMBER	DESCR.	ALT NOS.	APPLIC.	KG.	THICKNESS	BOLT	N°	NUT	N°
6Y0017	Cutting Edge		D10	104	35	5P8823	9	3K9770	9
6Y0311	Cutting Edge		D9, 992	125	35	4J9208	8	2J3507	8
6Y0312	Cutting Edge		D9	125	35	4J9208	8	2J3507	8
6Y5538	Cutting Edge		D9	155	29	4J9208	15	2J3507	15
6Y5539	Cutting Edge		D9	122	29	4J9208	12	2J3507	12
7J2957	Cutting Edge	4T6375	630, 631	140	35	4J9058	9	2J3507	9
7J2965	Cutting Edge		D9	137	41	8J2928	9	2J3507	9
7J2966	Cutting Edge		D9, 631, 637	106	41	8J2928	7	2J3507	7
7J2978	Cutting Edge	7J2878 4T6374	650	92	35	4J9058	12	2J3507	12
7J2980	Cutting Edge		D9	104	41	8J2928	7	2J3507	7
7J3026	Cutting Edge		637	140	35	4J9058	9	2J3507	9
7T4353	Cutting Edge		D8	103	41	4J9208	7	2J3507	7
7T5701	Cutting Edge		D9	196	35	4J9208	15	2J3507	15
7T5702	Cutting Edge		D9	155	35	4J9208	12	2J3507	12
7T6589	Cutting Edge		D7	51	25	6F0196	7	2J3505	7
7T6678	Cutting Edge		D7	47	25	6F0196B	6	2J3505	6
7T6936	Cutting Edge		D7	48	25	6F0196	6	2J3505	6
7T9125	Cutting Edge		D9, D8	69	35	4J9058	5	2J3507	5
7T9126	Cutting Edge		D9, D8	117	25	4J9208	9	2J3507	9
7T9779	Cutting Edge		D9	83	35	6V8360	5	3K9770	5
7T9782	Cutting Edge		D9	94	35	6V8360	6	3K9770	6
7V1490	Cutting Edge		966	253	40	5P8823	12	3K9770	12
7V4188	Cutting Edge		980	277	40	5P8823	12	3K9770	12
8K8161	Cutting Edge		920, 930, 950	108	25	8J2928	12	8J2933	12
8K8162	Cutting Edge		950	119	25	1J5607	10	2J3507	10
8K9754	Cutting Edge		966	181	32	4F4042	16	2J3507	16
9J4369	Cutting Edge		631, 637	161	35	4F4042	20	2J3507	20
9V6572	Cutting Edge		916, 924, 926, 941, 951, 953	104	25	1J5607	10	2J3507	10
9V6573	Cutting Edge		950, 960	184	32	4F4042	12	2J3507	12
9V6574	Cutting Edge		980	288	40	5P8823	12	3K9770	12
9V6575	Cutting Edge		960, 966, 970, 972	273	40	5P8823	12	3K9770	12
9W1878	Cutting Edge		D6	42	19	5J4773	8	2J3508	8
9W2425	Cutting Edge		D11	140	35	5P8823	9	3K9770	9
9W2426	Cutting Edge		D11	150	45	5P8823	9	3K9770	9
9W3927	Cutting Edge		D9	78	41	4J9208	5	2J3507	5

...continued

41122 Modena Italy
via delle Nazioni, 65

ph +39 059 9780111
fax +39 059 9780061
@ info@usco.it

part number are for reference purposes only

www.usco.it



USCO SpA



ITR PRODUCT CATALOGUE

PART NUMBER	DESCR.	ALT NOS.	APPLIC.	KG.	THICKNESS	BOLT N°	NUT N°
9W4396	Cutting Edge		D8	144	35	4J9058 11	2J3507 11
9W4493	Cutting Edge		D11	187	60	5P8823 9	3K9770 9
9W4494	Cutting Edge		D11	186	60	5P8823 9	3K9770 9
9W4500	Cutting Edge		D9	88	35	4J9058 7	2J3507 7
9W4502	Cutting Edge	1U4942	D9	102	35	1J4948 8	2J3507 8
9W4506	Cutting Edge	1U1562	D9	60	41	1J4948 6	2J3507 6
9W4507	Cutting Edge		D9	135	41	4J9208 9	2J3507 9
9W5232	Cutting Edge		D8	57	29	4F4042 5	2J3507 5
9W5432	Cutting Edge		D8	85	29	4F4042 8	2J3507 8
9W6608	Cutting Edge		D10	92	35	5P8823 5	3K9770 5
9W6609	Cutting Edge		D10	106	35	5P8823 6	3K9770 6
9W6615	Cutting Edge		D10	90	35	5P8823 5	3K9770 5
9W7043	Cutting Edge		D9	178	41	4J9208 12	2J3507 12
9W7044	Cutting Edge		D9	226	41	4J9208 15	2J3507 15
9W9098	Cutting Edge		D8	105	35	4F4042 8	2J3507 8

41122 Modena Italy
via delle Nazioni, 65

ph +39 059 9780111
fax +39 059 9780061
@ info@usco.it

part number are for reference purposes only

www.usco.it



USCO SpA



ITR PRODUCT CATALOGUE

2 c) Komatsu Cutting Edges

PART NUMBER	DESCR.	ALT NOS.	APPLIC.	KG.	THICKNESS	BOLT	N°	NUT	N°
130-70-41130	Cutting Edge		D53S-17 D58E-1B D65EX-12	37	19	02090-11270	17	02290-11219	17
130-70-61170	Cutting Edge		D53A-16 D53A-17 D57S-1	44	19	02090-11270	10	02290-11219	10
130-920-2180	Cutting Edge		D53P16/17 D60P-8 D65P-7 D65PX-12	33	19	02090-11270	12	02290-11219	12
144-70-11131	Cutting Edge	144-70-11130	D60P-8 D65A-8 D65E-8 D75S-2	48	19	02090-11270	11	02290-11219	11
144-920-1120	Cutting Edge		D65A-8 D65E-8	40	19	02090-01275	9	02290-01219	9
14X-71-11310	Cutting Edge		D65EX-12	40	19	02090-11265	9	02290-11219	9
154-70-11314	Cutting Edge	154-70-11313	D85A-12 D85A-18 D85E-18 D85E-21	55	25	154-70-11142	8	154-70-22270	8
154-81-11191	Cutting Edge	154-81-A1191 154-81-11190	D85A-12 D85A-18 D85E-18 D85E-21	55.8	19	154-70-11143	6	154-70-22270	6
175-70-21115	Cutting Edge		D155A-1	67	20	175-71-11454	9	175-71-11530	9
175-70-26310	Cutting Edge	175-71-26310	D150A-1 D135A-2 D155A-1 D155A-2 D155AX-3	51	25	175-71-11454	7	175-71-11530	7
17A-71-11351	Cutting Edge		D155AX-3	57	32	17M-71-12451	19	17M-71-21530	19
17M-71-21550	Cutting Edge		D27A-2	94	32	195-71-52280	7	17M-71-21530	7
195-70-12492	Cutting Edge		D375A-1 D455A-1	91	29	17A-71-12451	19	17M-71-21530	19
195-71-11654	Cutting Edge	195-71-11651 195-71-11653	D355A-3	92	32	195-71-11452	7	02290-11625	7
195-71-51651	Cutting Edge		D375A-1	92	32	195-71-52330	7	195-71-52340	7
195-71-51661	Cutting Edge		D375A-1	61	32	195-71-52330	5	195-71-52340	5
195-71-61550	Cutting Edge		D375A-2	111		198-71-21710	6	195-71-61950	6
195-72-11144	Cutting Edge		D355A-3	59	29	195-71-11452	13	02290-11625	13
198-71-11181	Cutting Edge		D375A-1 D375A-2 D375A-3 D455A-1 D475A-1	123	35	198-71-21710	13	195-71-61950	13
198-71-21830	Cutting Edge		D475A-1	145	38	198-71-21850	8	198-71-21910	8
198-71-31540	Cutting Edge	198-71-21840	D475A-2	105		198-71-21850	5	198-71-21910	5
198-72-11181	Cutting Edge		D375A-2	86	35	198-71-21710	5	195-71-61950	5

41122 Modena Italy
via delle Nazioni, 65

ph +39 059 9780111
fax +39 059 9780061
@ info@usco.it

part number are for reference purposes only

www.usco.it



USCO SpA

ERS



TRACK



ITR PRODUCT CATALOGUE



G.E.T. CATALOGUE CATALOGO PARTI USURA

3) *END BITS*

a) *Caterpillar End Bits*

b) *Caterpillar Grader End Bits*

c) *Komatsu End Bits*

41122 Modena Italy
via delle Nazioni, 65

ph +39 059 9780111
fax +39 059 9780061
@ info@usco.it

part number are for reference purposes only

www.usco.it



USCO SpA



ITR PRODUCT CATALOGUE

ITR END BITS



**The highest technical specifications
to guarantee the maximum wear life**

ELEMENT	END BIT %
Carbon	0,30 to 0,35
Silicon	0,15 to 0,30
Manganese	1,30 to 1,45
Phosphorus	0,030 max
Sulphur	0,040 max
Chromium	0,15 to 0,25

ELEMENT	END BIT %
<u>Molybdenum</u>	0,040 max
Nickel	0,20 max
Copper	0,30 max
Tin	0,040 max
Titanium	0,050 max
Boron	0,0005 to 0,0055

END BIT HARDNESS	
<u>SURFACE</u>	440 to 500 HB. (46 to 51 HRC)
<u>CENTRE</u>	440 HB minimum

END BIT STEEL TYPE
30MnCrB5

Chemical composition in % . HB - Hardness Brinell / HRC – Hardness Rockwell c.

41122 Modena Italy ph +39 059 9780111
 via delle Nazioni, 65 fax +39 059 9780061
 @ info@usco.it

part number are for reference purposes only

www.usco.it



ITR PRODUCT CATALOGUE

3 a) Caterpillar End Bits

PART NUMBER	DESCR.	APPLIC.	ALT NOS.	KG.	THICKNESS	BOLT	N°	NUT	N°
3G6395	End Bit	970, 973, 963, 966		26	35	5P8823	3	3K9770	3
3G8297	End Bit-R	D5, D6	6J0895	17.5	26	4F7827	6	2J3506	6
3G8298	End Bit-L		6J0896	17.5	26	4F7827	6	2J3506	6
3G8301	End Bit-R	D8	8J8117	30	32	4J9058	7	2J3507	7
3G8302	End Bit-L		8J8116	30	32	4J9058	7	2J3507	7
3G8315	End Bit	D7, D8	5J8767	35.5	32	5J2409	7	2J3505	7
3G8316	End Bit		5J8768	35.5	32	5J2409	7	2J3505	7
3G8317	End Bit-R	D8. 825	9J1477 8J8105 2Y2327	28	26	4J9058	7	2J3507	7
3G8318	End Bit		9J1478 8J8120 2Y2328	28	26	4J9058	7	2J3507	7
3G8319	End Bit-R	D6	6J0275	18.5	26	4F7827	6	2J3506	6
3G8320	End Bit-L		6J0276	18.5	26	4F7827	6	2J3506	6
4T8091	End Bit	951, 953, 943, 928	3G6993	10.5	26	1J5607		2J3507	
8E4193	End Bit-R	D8L, D8N	7T9089	51	38	4J9058	7	2J3507	7
8E4194	End Bit-L		7T9090	51	38	4J9058	7	2J3507	7
8E4196	End Bit-R	D9N, D9R	9W6192	60	51	4J9208	7	2J3507	7
8E4197	End Bit-L		9W6193	60	51	4J9208	7	2J3507	7
8E4543	End Bit-R	D10N, D11N	9W3675	169	60	5P8823	9	3K9770	9
8E4544	End Bit-L		9W3674	169	60	5P8823	9	3K9770	9
9W6198	End Bit-R	D7H, D7R	7T6588	51.5	38	6F0196	7	2J3505	7
9W6199	End Bit-L		7T6587	51.5	38	6F0196	7	2J3505	7
9W8874	End Bit-R	D6H, D6R		19.5	25	5J4773	5	2J3506	6
9W8875	End Bit-L			19.5	25	5J4773	5	2J3506	6



USCO SpA



ITR PRODUCT CATALOGUE

3 b) Caterpillar Grader End Bits



PART NUMBER	DESCR.	APPLIC.	ALT NOS.	KG.	THICKNESS	BOLT N°	NUT N°
6D1904	End Bit	12, 120, 130, 140	3F2819 3F2820 2C0103	9.5	13	4F3657	5 4K0367
6D1948	End Bit	12, 120, 140		12		4F3658	5 4K0367
7D2052	End Bit	12, 120, 140	3B4757	8	16	4F3657	5 4K0367
8E5529	End Bit	14G, 14H	6Y2801	8	16	5J4773	5 2J3506
8E5531	End Bit	120H, 140H	9W1764	8	16	3F5108	5 4K0367
9J4405	End Bit	14G	8D0164	8	16	5J4773	4 2J3506
9J4406	End Bit	14G	8D0165	8	16	5J4773	4 2J3506

41122 Modena Italy
via delle Nazioni, 65

ph +39 059 9780111
fax +39 059 9780061
@ info@usco.it

part number are for reference purposes only

www.usco.it



USCO SpA

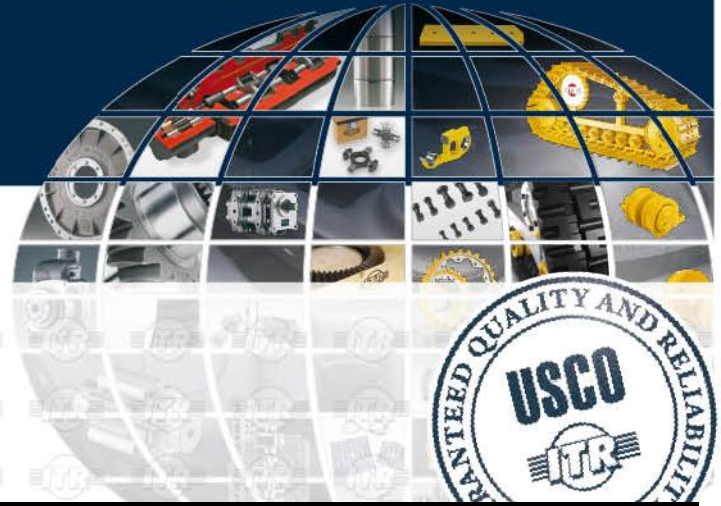

ITR PRODUCT CATALOGUE

3 c) Komatsu End Bits

PART NUMBER	DESCR.	APPLIC.	ALT NOS.	KG.	THICKNESS	BOLT N°	NUT N°		
144.70.11250	End Bit	D65	140.7011170	13.7	25	02091.11205	3	02290.11219	5
			140.70.11130			02090.11270	2		
144.70.11260	End Bit	D65	140.70.11180	13.7	25	02091.11205	3	02290.11219	5
			140.70.11131			02090.11270	2		
14X.71.11330	End Bit	D65EX-12		13,5	27	02090.11270	5	02290.11219	5
14X.71.11340	End Bit	D65EX-12		13,5	27	02090.11270	5	02290.11219	5
14Y.71.11330	End Bit	D65PX-12		11	25	02090.11270	5	02290.11219	5
14Y.71.11340	End Bit	D65PX-12		11	25	02090.11270	5	02290.11219	5
150.70.21346	End Bit	D85	150.70.21342	27	32	154.70.11142	6	154.70.22270	6
			150.70.21343						
			150.70.21344						
			150.70.21345						
150.70.21356	End Bit	D85	150.70.21352	27	32	154.70.11142	6	154.70.22270	6
			150.70.21353						
			150.70.21354						
			150.70.21355						
175.70.21126	End Bit	D155A-2		30	32	175.71.11463	7	175.71.11530	7
175.70.21136	End Bit	D155A-2		30	32	175.71.11463	7	175.71.11530	7
175.71.22272	End Bit	D155	175.71.22270	36	37	175.71.11462	7	175.71.11530	7
			175.71.22271						
175.71.22282	End Bit	D155	175.71.22280	36	37	175.71.11462	7	175.71.11530	7
			175.71.22281						
175.71.22272HD	End Bit	D155		38.5	40	175.71.11462	7	175.71.11530	7
175.71.22282HD	End Bit	D155		38.5	40	175.71.11462	7	175.71.11530	7
17M.71.21930	End Bit	D275		74.5	38	195.71.52280	7	17M.71.21530	7
17M.71.21940	End Bit	D275		74.5	38	195.71.52280	7	17M.71.21530	7
195.71.11173	End Bit	D355	195.71.11172	63	38	195.71.11451	7	02290.11625	7
			195.71.11170						
			195.71.11171						
			195.71.21350						
195.71.11183	End Bit	D355	195.71.11182	63	38	195.71.11451	7	02290.11625	7
			195.71.11180						
			195.71.11181						
			195.71.21360						
195.71.11173HD	End Bit	D355		67	40	198.71.21720	8	198.71.61950	8
195.71.11183HD	End Bit	D355		67	40	198.71.21720	8	198.71.61950	8
195.71.61930	End Bit	D375		131	50	198.71.21720	8	198.71.61950	8
195.71.61940	End Bit	D375		131	50	198.71.21720	8	198.71.61950	8

41122 Modena Italy
via delle Nazioni, 65

ph +39 059 9780111
fax +39 059 9780061
@ info@usco.it

part number are for reference purposes only

www.usco.it

52



USCO SpA



ERS



TRACK ONE



ITR PRODUCT CATALOGUE

G.E.T. CATALOGUE CATALOGO PARTI USURA

4) GRADER BLADES

a) Caterpillar Grader Blades

b) Komatsu Grader Blades

c) Caterpillar and Komatsu Grader Blades
by size

41122 Modena Italy
via delle Nazioni, 65

ph +39 059 9780111
fax +39 059 9780061
@ info@usco.it

part number are for reference purposes only

www.usco.it



USCO SpA



ITR PRODUCT CATALOGUE

ITR GRADER BLADES



**The highest technical specifications
to guarantee the maximum wear life**

GRADER BLADES HARDNESS	
CARBON STEEL	250 HB MIN
BORON STEEL	450 HB MIN

41122 Modena Italy
via delle Nazioni, 65

ph +39 059 9780111
fax +39 059 9780061
@ info@usco.it

part number are for reference purposes only

www.usco.it



USCO SpA



ITR PRODUCT CATALOGUE

4 a) Caterpillar Grader Blades

PART NUMBER	DESCR.	APPLIC.	BOLT	N°	NUT	N°
5D9553	GRADER BLADE	120, 120B, 120G, 120H, 120H ES, 120H NA, 130G, 135H, 135H NA, 140, 140, 140H, 140H ES, 140H NA, 12F, 12G, 12H, 12H ES, 12H NA, 14E, 14G, 16, 16G	3F5108	13	4K0367	13
5D9554	GRADER BLADE	120G, 140G, 14E, 12E	3F5108	15	4K0367	15
7D1158	GRADER BLADE	160H, 14H NA, 14G, 14H, 160H, 120G, 140G, 140H NA, 135H NA, 120H NA, 12H NA, 130G, 163H, 143H, 160H ES, 160H NA, 140H ES	5J4773	15	2J3506	15
5D9561	GRADER BLADE	16, 140H, 12H, 120H, 140H, 140H ES, 143H, 12H ES, 135H, 143 H, 12H NA	3F5108	15	4K0367	15
5D9562	GRADER BLADE	16, 140H, 12H, 120H, 140H, 140H ES, 143H, 12H ES, 135H, 143 H, 12H NA	3F5108	13	4K0367	13
5D9558	GRADER BLADE					
5D9559	GRADER BLADE	140B, 130G, 120G, 16, 140G, 12G, 140H, 12G, 140H, 135H, 120H, 12H, 140H, 160H, 120H ES, 12H ES, 140H ES, 120H NA	3F5108	15	4K0367	15
7D9999	END BIT	93U, 49G, 90Z, 91Z, 16G, 16, 657E	1J6762	8	2J3506	8
6Y2805	END BIT	160H, 160H ES, 140H ES, 140H NA, 12H, 140H, 143H, 163H, 163H NA, 160H NA	1J6762	8	2J3506	8

41122 Modena Italy
via delle Nazioni, 65

ph +39 059 9780111
fax +39 059 9780061
@ info@usco.it

part number are for reference purposes only

www.usco.it



USCO SpA



ITR PRODUCT CATALOGUE

4 b) Komatsu Grader Blades

PART NUMBER	DESCR.	APPLIC.	BLADE LENGTH	BOLT N°	NUT N°
233-70-12141	GRADER BLADE	GD313, GD461	1522 mm	232-70-12580 9	232-70-12480 9
232-70-12143	GRADER BLADE	GD510, GD511, GD521, GD523, GD525, GD611, GD621, GD623, GD625, GD661	1826 mm	232-70-12450 9	232-70-12480 9
234-70-12710	GRADER BLADE	GD705, GD725	2133 mm	234-70-32230 13	234-70-32290 13
235-70-12140	GRADER BLADE	GD825	2436 mm	234-70-32260 16	234-70-32290 16
232-70-52190	END BIT	GD510, GD511, GD521, GD523, GD525, GD605, GD621, GD623, GD625, GD661		232-70-12460 6	232-70-12480 6
232-70-52191	END BIT				
234-70-32230	END BIT				
234-70-32240	END BIT				

41122 Modena Italy
via delle Nazioni, 65

ph +39 059 9780111
fax +39 059 9780061
@ info@usco.it

part number are for reference purposes only

www.usco.it



USCO SpA



ITR PRODUCT CATALOGUE

4 c) Caterpillar and Komatsu Grader Blades by size

BLADE HEIGHT	BLADE LENGTH	PART NUMBER	BLADE THICKNESS	BOLT TYPE
6''(152MM)	5' (1522mm)	9J3862	1/2" (13mm)	5/8
		7D4508	5/8" (16mm)	5/8
		3G7966	3/4" (19mm)	5/8
		233-70-12141	1/2" (13mm)	5/8
		238-70-12220	5/8" (16mm)	5/8
	6' (1826mm)	8D2786	1/2" (13mm)	5/8
		9J3660	1/2" (13mm)	3/4
		5D9553	5/8" (16mm)	5/8
		9J3657	5/8" (16mm)	3/4
		5D9556	3/4" (19mm)	5/8
		232-70-12143	5/8" (16mm)	5/8
	7' (2133mm)	8D2787	1/2" (13mm)	5/8
		9J3659	1/2" (13mm)	3/4
		5D9554	5/8" (16mm)	5/8
		9J3658	5/8" (16mm)	3/4
		5D9557	3/4" (19mm)	5/8
		234-70-12193	5/8" (16mm)	5/8
		234-70-12192	1/2" (13mm)	5/8
	8' (2436mm)	8J7782	1/2" (13mm)	5/8
		9J3656	1/2" (13mm)	3/4
8J4043		5/8" (16mm)	5/8	
9J3655		5/8" (16mm)	3/4	

...continued

41122 Modena Italy
via delle Nazioni, 65

ph +39 059 9780111
fax +39 059 9780061
@ info@usco.it

part number are for reference purposes only

www.usco.it



USCO SpA



ITR PRODUCT CATALOGUE

BLADE HEIGHT	BLADE LENGTH	PART NUMBER	BLADE THICKNESS	BOLT TYPE
8" (203MM)	5' (1522mm)	9J3863	1/2" (13mm)	5/8
		7D4509	5/8" (16mm)	5/8
		9W6252	3/4" (19mm)	5/8
		4T2240	1" (25mm)	5/8
	6' (1826mm)	8D2788	1/2" (13mm)	5/8
		5D9562	5/8" (16mm)	5/8
		5D9558	3/4" (19mm)	5/8
		4T2244	1" (25mm)	5/8
		4T2231	1" (25mm)	3/4
		232-70-52850	3/4" (19mm)	5/8
		8D2789	1/2" (13mm)	5/8
		5D9561	5/8" (16mm)	5/8
	7' (2133mm)	7D1158	5/8" (16mm)	3/4
		5D9559	3/4" (19mm)	5/8
		7D1577	3/4" (19mm)	3/4
		4T2242	1" (25mm)	5/8
		4T2233	1" (25mm)	3/4
		234-70-12670	3/4" (19mm)	5/8
		234-70-12710	5/8" (16mm)	3/4
		8J8980	1/2" (13mm)	5/8
	8' (2436mm)	5D9731	5/8" (16mm)	5/8
		8J9821	5/8" (16mm)	3/4
		5D9732	3/4" (19mm)	5/8
		7D1949	3/4" (19mm)	3/4
4T2237		1" (25mm)	5/8	
235-70-12140		3/4" (19mm)	3/4	

41122 Modena Italy
via delle Nazioni, 65

ph +39 059 9780111
fax +39 059 9780061
@ info@usco.it

part number are for reference purposes only

www.usco.it



USCO SpA



ITR PRODUCT CATALOGUE

G.E.T. CATALOGUE CATALOGO PARTI USURA



5) RIPPER SHANKS

a) *Caterpillar Ripper Shanks*

b) *Komatsu Ripper Shanks*

41122 Modena Italy
via delle Nazioni, 65

ph +39 059 9780111
fax +39 059 9780061
@ info@usco.it

part number are for reference purposes only

www.usco.it



USCO SpA



ITR PRODUCT CATALOGUE

ITR RIPPER SHANKS

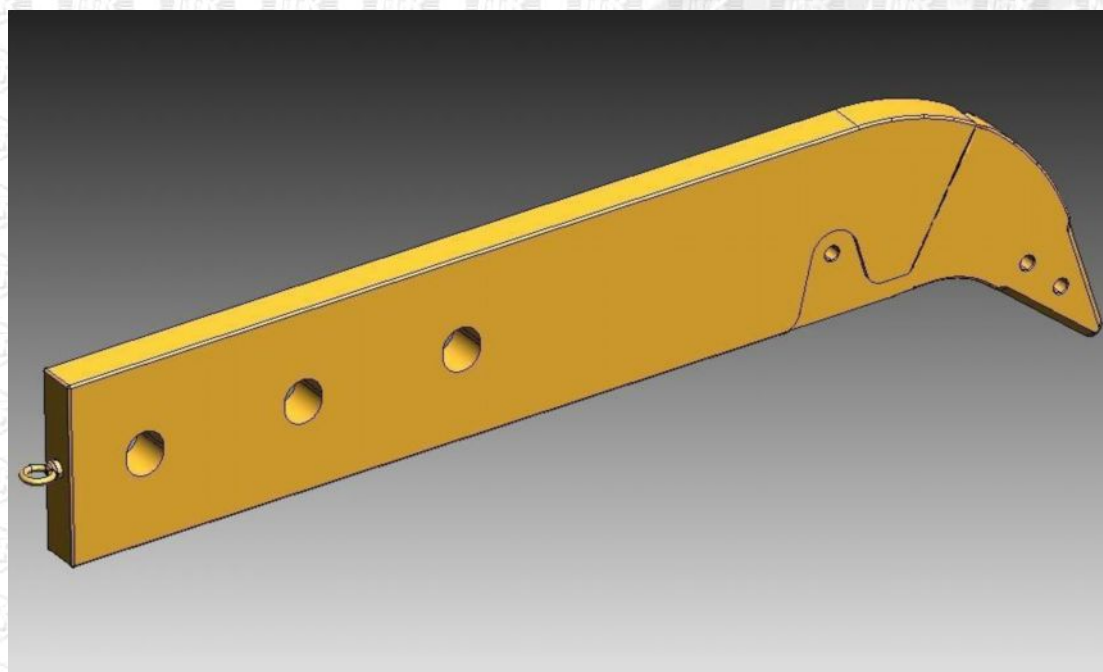

The highest technical specifications to guarantee the maximum wear life

41122 Modena Italy
via delle Nazioni, 65

ph +39 059 9780111
fax +39 059 9780061
@ info@usco.it

part number are for reference purposes only

www.usco.it

60



USCO SpA



ITR PRODUCT CATALOGUE

5 a) Caterpillar Ripper Shanks

PART NUMBER	DESCR.	APPLIC.	ALT NOS.	DIMENSIONS	KG.	PROTECTOR	RIPPER TIP
1049279	ADAPTER	D11N, D11R			125	9N4621	
1U3630	ADAPTER	D9L, D10, D10N			107	1U3644	
8E8418	ADAPTER	D8, D8L, D9			78	8J8414	
1038115	ADAPTER	D9L, D10N, D10R, D10			72	9W8365	
9J3139	SHANK	D6, D5, 16, 977		73 x 176 x 711	56	/	6Y0359
9J6586	SHANK	955, 951, 941, D5M		59 x 138 x 533	30	/	6Y0359
9J8923	SHANK	D6, D5, 977, 973		73 x 176 x 667	50	/	6Y0359
9W7382	SHANK	D7H/ D7R			140	/	6Y0359
8E5339	SHANK	D9N		75 x 333 x 2332	420	6J8814	9W2451
8E5346	SHANK	D8N/D8R, D9N/D9R		75 x 330 x 1610		8E1848	9W2451
8E5347	SHANK	D8R		72 x 332 x 2010	360	8E1848	9W2451
8E5348	SHANK	D8N/D8R D9N/D9R		75 x 330 x 2760	510	8E1848	9W2451
8E8414	SHANK	D9L, D10N	6Y6138	89 x 356 x 2325	625	9W8365	4T4501
1073486	SHANK	D9H, D8K	7J1793	90 x 355 x 2700	600	6J8814	9W2451
1099114	SHANK	D9		90 x 355 x 2825	680	1U3644	4T4501
1144503	SHANK	D9		90 x 355 x 2325	570	1U3644	4T4501

41122 Modena Italy
via delle Nazioni, 65

ph +39 059 9780111
fax +39 059 9780061
@ info@usco.it

part number are for reference purposes only

www.usco.it



USCO SpA



ITR PRODUCT CATALOGUE



5 b) Komatsu Ripper Shanks

PART NUMBER	DESCR.	APPLIC.	DIMENSIONS	KG.	PROTECTOR	RIPPER TIP
175-79-32131	SHANK	D155	75 x 320 x1600	480	195.78.21320	175.78.31230
175-78-21693	ADAPTER	D155	76 x 178	94	195.78.21320	175.78.31230
17M-79-21320	SHANK	D275			17M.78.21330	195.78.21331
195-79-31141	SHANK	D355	90 x 400 x 2350	550	195.78.21320	195.78.21331
195-78-71380	ADAPTER	D355	76 x 351	128	195.78.21320	195.78.21331
195-79-51151	SHANK	D375	95 x 400 x 2350	560	195.78.71111	195.78.71320

41122 Modena Italy
via delle Nazioni, 65

ph +39 059 9780111
fax +39 059 9780061
@ info@usco.it

part number are for reference purposes only

www.usco.it



USCO SpA



ITR PRODUCT CATALOGUE

PICKS FOR ROAD REHABILITATION



**The highest technical specifications
to guarantee the maximum wear life**

41122 Modena Italy
via delle Nazioni, 65

ph +39 059 9780111
fax +39 059 9780061
@ info@usco.it

part number are for reference purposes only

www.usco.it

63



USCO SpA



ITR PRODUCT CATALOGUE

6) ITR PICKS FOR ROAD REHABILITATION



PICKS FOR ROAD REHABILITATION

PART NUMBER	DESCR.	EQUIPMENT LOW/HIGH POWER	PAVEMENT APPLICATION			
			SOFT ASPHALT	MEDIUM ASPHALT	HARD ASPHALT	CONCRETE
URP05	Ø 20mm, NO puller groove	L	X	X	X	
URP18	Ø 20mm, puller groove	L	X	X	X	
URP19	Ø 20mm, NO puller groove	H			X	X
URP21	Ø 20mm, puller groove	H				X
URP22	Ø 20mm, puller groove	L				X
URP24	Ø 20mm, puller groove	L	X	X	X	
URP28	Ø 20mm, puller groove	L	X	X		
URS16	Ø 20mm, puller groove	H				X
URS18	Ø 20mm, puller groove	L	X	X		
URZ05	Ø 20mm, NO puller groove	L	X	X	X	
URZ07	Ø 20mm, NO puller groove	L			X	X
URZ19	Ø 20mm, NO puller groove	H				X
URZ24	Ø 20mm, puller groove	L	X	X	X	
UW6	Ø 20mm, puller groove	L	X	X	X	

...continued

41122 Modena Italy
via delle Nazioni, 65

ph +39 059 9780111
fax +39 059 9780061
@ info@usco.it

part number are for reference purposes only

www.usco.it

64



USCO SpA



ITR PRODUCT CATALOGUE



PICKS FOR ROAD REHABILITATION

PART NUMBER	DESCR.	EQUIPMENT LOW/HIGH POWER	PAVEMENT APPLICATION			
			SOFT ASPHALT	MEDIUM ASPHALT	HARD ASPHALT	CONCRETE
URP10	Ø 20mm, puller groove	H	X		X	X
URP15	Ø 20mm, puller groove	H				X
URP16	Ø 20mm, puller groove	H		X	X	
URP18	Ø 20mm, puller groove	L	X	X	X	
URP24	Ø 20mm, NO puller groove	H	X	X	X	
URP25	Ø 20mm, NO puller groove	H		X	X	X
URP27	Ø 20mm, puller groove	L		X	X	X
URZ05	Ø 20mm, NO puller groove	H	X	X		
URZ08	Ø 20mm, NO puller groove	H			X	
URZ16	Ø 20mm, NO puller groove	L			X	X
URZ20	Ø 20mm, NO puller groove	H			X	
URZ24	Ø 20mm, NO puller groove	H	X	X		

41122 Modena Italy
via delle Nazioni, 65

ph +39 059 9780111
fax +39 059 9780061
@ info@usco.it

part number are for reference purposes only

www.usco.it

65



USCO SpA



ITR PRODUCT CATALOGUE



PICKS FOR ROAD REHABILITATION

PART NUMBER	DESCR.	EQUIPMENT LOW/HIGH POWER	STABILIZATION APPLICATION			
			ASPHALT	CONCRETE	ROCK ASPHALT	SOIL
UM3	Ø 19,4mm, puller groove	L	X			
URC01	Ø 19,9mm, NO PULLER	H			X	X
URP01	Ø 20mm, NO puller Groove	L/H			X	X
URP05	Ø 20mm, NO puller groove	H				X
URP06	Ø 20mm, NO puller groove	L			X	
URP07	Ø 20mm, NO puller groove	H	X			
URP10	Ø 20mm, puller groove	L				X
URP15	Ø 20mm, puller groove	L/H			X	
URP26	Ø 20mm, NO puller groove	H	X			
URZ07	Ø 20mm, NO puller groove	H	X			
URZ08	Ø 20mm, NO puller groove	H	X			
URZ19	Ø 20mm, NO puller groove	H			X	
URZ20		H	X			
USM01	Ø 22mm, puller groove	L				X
USM02	Ø 22mm, puller groove	L			X	X
USM03	Ø 22mm, puller groove	L/H	X			X
USM04	Ø 22mm, puller groove	L/H	X		X	
USR01	Ø 22mm, NO puller groove	H				X
USR03	Ø 22mm, NO puller groove	H	X		X	
USR04	Ø 22mm, NO puller groove	H			X	X
UW6.22	Ø 22mm, NO puller groove	H			X	X

41122 Modena Italy
via delle Nazioni, 65

ph +39 059 9780111
fax +39 059 9780061
@ info@usco.it

part number are for reference purposes only

www.usco.it



USCO SpA



ITR PRODUCT CATALOGUE



PICKS FOR ROAD REHABILITATION

PART NUMBER	DESCR.	EQUIPMENT LOW/HIGH POWER	SOIL APPLICATION			
			ASPHALT	CONCRETE	ROCK ASPHALT	SOIL
USM05	Ø 22mm, NO puller groove	L/H		X	X	
USM06	Ø 22mm, puller groove	L/H		X	X	
UC31HD	Ø 25mm, puller groove	L/H		X	X	
UC3KBF	Ø 19mm, puller groove	L/H	X			

PICKS FOR ROAD REHABILITATION

PART NUMBER	DESCR.	EQUIPMENT LOW/HIGH POWER	SOIL APPLICATION TRENCHING MACHINES			
			ASPHALT	CONCRETE	ROCK ASPHALT	ABRASIVE SOIL
UC3R	Ø 19mm, NO puller groove	L/H	X		X	X
UC21HD	Ø 19mm, puller groove	L/H		X	X	
UTS30	Ø 30mm, NO puller groove	L/H			X	X
URL09	Ø 19mm, puller groove	L/H			X	X
URL10	Ø 19mm, puller groove	L/H		X	X	

Ed 4 - Revised JUNE 2009

41122 Modena Italy
via delle Nazioni, 65

ph +39 059 9780111
fax +39 059 9780061
@ info@usco.it

part number are for reference purposes only

www.usco.it

67